



WAM®



3

SPARE PARTS



MU - BU

- **LIVE BIN BOTTOMS**
SPARE PARTS CATALOGUE
- **SCHNECKENAUSTRAGEBÖDEN**
ERSATZTEILKATALOG
- **EXTRACTEURS MULTIPLES À VIS**
PIECES DE RECHANGE
- **ESTRATTORI MULTIPLI A COCLEA**
PEZZI DI RICAMBIO

CATALOGUE No.			CREATION DATE
ISSUE A	CIRCULATION 100	DATE OF LATEST UPDATE WA. 01520 R.	12 - 2004



WAM®

All the products described in this catalogue are manufactured according to **WAMGROUP S.p.A. Quality System procedures**. The Company's Quality System, certified in July 1994 according to International Standards **UNI EN ISO 9002** and extended to the latest release of **UNI EN ISO 9001**, ensures that the entire production process, starting from the processing of the order to the technical service after delivery, is carried out in a controlled manner that guarantees the quality standard of the product.

*Alle in diesem Katalog beschriebenen Produkte werden gemäß dem **Qualitätssystem der WAMGROUP S.p.A.** hergestellt. Das im Juli 1994 gemäß der internationalen Norm **UNI EN ISO 9002** und auf die neueste Version der **UNI EN ISO 9001** erweiterte, zertifizierte Qualitätssystem der Firma gewährleistet, dass der gesamte Produktionsprozess von der Auftragsbearbeitung bis zum technischen Kundendienst nach Lieferung in kontrollierter Art und Weise erfolgt, so dass der Qualitätsstandard des Produkts gewährleistet ist.*

Tous les produits décrits dans ce catalogue sont fabriqués selon les procédures du **Système de Qualité de WAMGROUP S.p.A.**, certifié en Juillet 1994 selon les normes internationales **UNI EN ISO 9002** et étendu à la dernière version de la norme **UNI EN ISO 9001**. Cela garantit que le processus de production, à partir de la gestion de la commande au service technique après-vente, est effectué de manière contrôlée garantissant la norme de qualité du produit.

*Tutti i prodotti descritti nel catalogo sono stati realizzati secondo le **procedure del Sistema Qualità di WAMGROUP S.p.A.** Il Sistema Qualità aziendale, certificato dal luglio 1994 in conformità alle normative internazionali **UNI EN ISO 9002** e successivamente esteso all'ultima versione delle normative **UNI EN ISO 9001**, garantisce che l'intero processo produttivo, dalla formulazione dell'ordine fino all'assistenza tecnica dopo la consegna, si svolge secondo modalità controllate che garantiscono lo standard qualitativo del prodotto.*

This publication cancels and replaces any previous edition and revision.
We reserve the right to implement modifications without notice.
This catalogue cannot be reproduced, even partially, without prior consent.

*Diese Veröffentlichung storniert und ersetzt alle früheren Ausgaben und überarbeiteten Fassungen.
Wir behalten uns das Recht vor, Änderungen ohne vorherige Information durchzuführen.
Dieser Katalog darf ohne vorherige Genehmigung weder ganz noch teilweise vervielfältigt werden.*

Cette publication annule et remplace toute édition et révision antérieure.
Nous nous réservons le droit de mettre en place des modifications sans préavis.
Ce catalogue ne peut être reproduit, même partiellement, sans notre consentement préalable.

*Questa pubblicazione annulla e sostituisce le edizioni e revisioni precedenti.
Ci riserviamo la facoltà di apportare modifiche senza preavviso.
Il presente catalogo non può essere riprodotto, nemmeno parzialmente, senza previo consenso.*



1 TECHNICAL CATALOGUE

CODE INDEX
 INTRODUCTION
 STANDARD SUPPLY
 ACCESSORIES
 OVERALL DIMENSION AN-TYPE
 MU_P - MU_E STRUCTURAL COMPONENTS
 MU_S STRUCTURAL COMPONENTS
 MU_P - MU_E MECHANICAL COMPONENTS
 DIRECT DRIVE (S-TYPE GEAR REDUCER)
 DRIVE UNIT LAYOUT
 FINISHING
 COLOURS
 MU TYPE MODULAR CODE KEY
 INQUIRY FORM
 MEDIUM-HEAVY DUTY TROG
 EXTRA-HEAVY DUTY TROG
 TROUGH FLANGE DRILLING
 END PLATE XP - TYPE
 END PLATE
 DRILLING SCHEME
 SCREW DIRECTION AND ROTATION
 P SCREW
 E SCREW
 XJQ - TYPE COVER SUPPORT BRACKET
 TROUGH COVER
 COVER LOCK
 END BEARING ASSEMBLY TYPE - XSP
 END BEARING ASSEMBLY TYPE - XSR
 SHAFT SEALING TYPE - XUC
 SHAFT COUPLINGS XAA and XAC
 SHAFT COUPLING XAV
 GEAR REDUCER - TYPE S 21-23-25-27
 MOTOR MT
 OPTIONS - XAL SPLINED AND BOLTED SHAFT COUPLING
 OPTIONS - SHAFT COUPLINGS XAQ-XAT
 OPTIONS - COUPLING TRANSMISSION ("S"-TYPE GEAR REDUCER)
 OPTIONS - CHAIN TRANSMISSION ("S"-TYPE GEAR REDUCER)
 OPTIONS - SCREW WITH BLADES
 OPTIONS - XSQ END BEARING ASSEMBLY
 OPTIONS - XSS END BEARING ASSEMBLY
 ACCESSORIES - SQUARE INLET
 ACCESSORIES - XFBA - TYPE OVERFLOW HATCH FLAP
 ACCESSORIES - FLOW STOPPING DIAPHRAGM XJE
 ACCESSORIES - XKX-TYPE FINGER MESH BENEATH HATCH FLAP
 ACCESSORIES - TUBULAR INSERT XJG
 ACCESSORIES - MEMBRANE HATCH
 ACCESSORIES - ROTATIONAL INDICATOR BRACKET XVA
 ACCESSORIES - TROUGH FOOT TYPE XJS
 ACCESSORIES - ADDITIONAL PURGED SHAFT SEAL
 ACCESSORIES - INSPECTION HATCH
 ACCESSORIES - REINFORCEMENT RINGS
 OPTIONS - QUICK REMOVABLE SCREW
 TROUGH CONFIGURATION Ø 100 - 250
 SHIPPING DATA
 WEIGHTS MU_P
 WEIGHTS MU_E AN
 WEIGHTS MU_E AN

1 TECHNISCHER KATALOG

CODES T. 5
 EINFÜHRUNG 6
 STANDARD-LIEFERUMFANG 7
 ZUBEHÖR 8
 EINBAUMASSE TYP AN 9
 STAHLBAUTEILE MU_P - MU_E 10
 STAHLBAUTEILE MU_S 11
 MECHANISCHE KOMPONENTEN MU_P - MU_E 12
 DIREKTANTRIEB (S-GETRIEBE) 13
 ANTRIEBSANORDNUNG 14 →, 16
 FINISH 17
 FARBTÖNE 18
 SUCHCODESCHLÜSSEL TYP MU 19 →, 21
 ANFRAGEFORMULAR 22 →, 25
 TROG MITTELSCHWER 26
 TROG SCHWER 27
 TROGFANSHLOCHBILD 28
 ENDSCHILD XP 29
 ENDSCHILD 30 →, 31
 BOHRPLAN 31 →, 38
 SCHRAUBENRICHTUNG UND DREHSINN 39
 SCHNECKENWENDEL P 40
 SCHNECKENWENDEL E 41
 ABDECKUNGSAUFLAGEBÜGEL TYP XJQ 42
 TROGABDECKUNG 43
 ABDECKUNGSVERSCHLUSS 44
 ENDLAGEREINHEIT XSP 45
 ENDLAGEREINHEIT XSR 46
 WELLENABDICHTUNG TYP XUC 47
 WELLENVERBINDUNGEN XAA und XAC 48
 WELLENVERBINDUNG XAV 49
 GETRIEBE TYP S 21-23-25-27 50 →, 51
 MOTOR MT 52 →, 53
 VARIANTEN - VIELKEILWELLENVERBINDUNG VERSTIFTET XAL 54
 VARIANTEN - WELLENVERBINDUNG XAQ-XAT 55
 VARIANTEN - KUPPLUNG (GETRIEBE TYP "S") 56
 VARIANTEN - KETTENTRIEB (GETRIEBE TYP "S") 57
 VARIANTEN - PADDELWENDEL 58
 VARIANTEN - ENDLAGEREINHEIT TYP XSQ 59
 VARIANTEN - ENDLAGEREINHEIT TYP XSS 60
 ZUBEHÖR - EINLAUF 61
 ZUBEHÖR - ÜBERLAUFKLAPPE TYP XFBA 62
 ZUBEHÖR - DURCHFLUSSSPERRE XJE 63
 ZUBEHÖR - SCHUTZGITTER TIP XKX UNTER ÜBERLAUFKLAPPE 64
 ZUBEHÖR - VERDRÄNGUNGSELEMENT XJG 65
 ZUBEHÖR - MEMBRANKLAPPE 66
 ZUBEHÖR - SOCKEL FÜR ROTATIONSMELDER XVA 67
 ZUBEHÖR - TROGFUSS TYP XJS 68
 ZUBEHÖR - ZUSÄTZLICHE WELLENABDICHTUNG MIT SPERRSPÜLUNG 69
 ZUBEHÖR - INSPEKTIONSKLAPPE 70
 ZUBEHÖR - VERSTÄRKUNGSRINGE 71
 VARIANTEN - SCHNELLE HERAUSZIEHBARE WENDEL 72
 TROGKONFIGURATION Ø 100 - 250 73
 KOLLIDATEN 74
 GEWICHTE MU_P 75
 GEWICHTE MU_E AN 76

2 MAINTENANCE CATALOGUE
 OPERATION AND MAINTENANCE

2 WARTUNGSKATALOG
 BETRIEBS- UND WARTUNGSANLEITUNG M. 4 →, 23

3 SPARE PARTS CATALOGUE

SPARE PARTS
 SPARE PARTS - GENERAL VIEW
 SPARE PARTS
 SPARE PARTS - XSP-XSR END BEARING
 SPARE PARTS - XUC SHAFT SEALING
 SPARE PARTS

3 ERSATZEILKATALOG

ERSATZEILKATALOG R. 5
 ERSATZEILKATALOG - ÜBERSICHT 6
 ERSATZEILKATALOG 4
 ERSATZEILKATALOG - ENDLAGEREINHEIT XSP-XSR 8 →, 12
 ERSATZEILKATALOG - WELLENABDICHTUNG XUC 13 →, 16
 ERSATZEILKATALOG 17 →, 43

1	CATALOGUE TECHNIQUE	1	CATALOGO TECNICO	
	CODES ET SIGLES.....		CODICI E SIGLE.....	T. 5
	INTRODUCTION.....		INTRODUZIONE.....	6
	COMPOSITION STANDARD.....		FORNITURA STANDARD.....	7
	ACCESSOIRES.....		ACCESSORI.....	8
	ENCOMBREMENT TYPE AN.....		INGOMBRI COCLEA TIPO AN.....	9
	COMPOSANTS STRUCTURE MU_P - MU_E.....		COMPONENTI COMPONENTI CARPENTERIA MU_P - MU_E.....	10
	COMPOSANTS STRUCTURE MU_S.....		COMPONENTI COMPONENTI CARPENTERIA MU_S.....	11
	COMPOSANTS MECANIQUE MU_P - MU_E.....		COMPONENTI MECCANICA MU_P - MU_E.....	12
	ENTRAINEMENT DIRECTE (REDUCTEUR TYPE "S").....		MOTORIZZAZIONE DIRETTA (TESTATA MOTRICE TIPO "S").....	13
	POSITIONS DES MOTORISATIONS.....		DISPOSIZIONE MOTORIZZAZIONI.....	14 → 16
	FINITION.....		FINITURA.....	17
	TONALITES.....		TONALITÀ.....	18
	CODE MODULAIRE TYP MU.....		CHIAVE SIGLA MODULARE TIPO MU.....	19 → 21
	FICHE DE DOMANDE.....		MODULO RICHIESTA.....	22 → 25
	AUGE SERVICE LOURD.....		TRUOGOLO PESANTE.....	26
	AUGE EXTRA LOURD.....		TRUOGOLO EXTRAPESANTE.....	27
	PERÇAGE BRIDE AUGE.....		FORATURA FLANGIA TRUOGOLO.....	28
	FLASQUE COTE XP.....		PORTASUPPORTO XP.....	29
	FLASQUE.....		PORTASUPPORTO.....	30 → 31
	SCHEMA DE PERÇAGE.....		SCHEMA DI FORATURA.....	31 → 38
	SENS DE L'HÉLICE ET SENS DE ROTATION.....		SENSO DELL'ELICA E VERSO DI ROTAZIONE.....	39
	SPIRE P.....		SPIRA P.....	40
	SPIRE E.....		SPIRA E.....	41
	SUPPORT CAPOT XJQ.....		SOTTOCOPERCHIO XJQ.....	42
	CAPOTAGE.....		COPERCHIO.....	43
	FERMETURE CAPOTAGE.....		CHIUSURA COPERCHIO.....	44
	SUPPORT PALIER D'EXTREMITÉ TYPE XSP.....		SUPPORTO D'ESTREMITÀ XSP.....	45
	SUPPORT PALIER D'EXTREMITÉ TYPE XSR.....		SUPPORTO D'ESTREMITÀ XSR.....	46
	ETANCHEITE TYP XUC.....		TENUTA XUC.....	47
	ACCOUPEMENTS XAA et XAC.....		ACCOPIAMENTI XAA e XAC.....	48
	ACCOUPEMENT XAV.....		ACCOPIAMENTO XAV.....	49
	REDUCTEUR TYPE S 21-23-25-27.....		TESTATA MOTRICE S 21-23-25-27.....	50 → 51
	MOTEUR MT.....		MOTORE MT.....	52 → 53
	OPTIONS- ACCOUPLEMET CANNELE ET DEFONCE XAL.....		OPZIONI - ACCOPIAMENTO CALETTATO SPINATO XAL.....	54
	OPTIONS- ACCOUPLEMETS XAQ-XAT.....		OPZIONI - ACCOPIAMENTI XAQ-XAT.....	55
	OPTIONS - ENTRAINEM. AV.ACCOUP. DEMI-ELASTIQUE (RED. TYPE "S").....		OPZIONI - TRASMISSIONE CON GIUNTO (TEST.MOTR.TIPO "S").....	56
	OPTIONS - ENTRAINEMENT PAR CHAINE (REDUCTEUR TYPE "S").....		OPZIONI - TRASMISSIONE A CATENA (TEST.MOTR.TIPO "S").....	57
	OPTIONS - SPIRE A PALETTES.....		OPZIONI - ELICIA PALETTE.....	58
	OPTIONS - SUPPORT PALIER D'EXTREMITÉ TYPE XSQ.....		OPZIONI - SUPPORTO D'ESTREMITÀ XSQ.....	59
	OPTIONS - SUPPORT PALIER D'EXTREMITÉ TYPE XSS.....		OPZIONI - SUPPORTO D'ESTREMITÀ XSS.....	60
	ACCESSOIRES - BOUCHE D'ENTREE.....		ACCESSORI - BOCCA CARICO.....	61
	ACCESSOIRES - CAPOT MOBILE XFBA.....		ACCESSORI - PORTELLO XFBA.....	62
	ACCESSOIRES - DIAPHRAGME ARRET DE FLUX XJE.....		ACCESSORI - DIAFRAMMA FERMAFLUSSO XJE.....	63
	ACCESSOIRES - GRILLE SOUS CAPOT MOBILE XKX.....		ACCESSORI - RETE SOTTOPORTELLO XKX.....	64
	ACCESSOIRES - INSERT TUBULAIRE XJG.....		ACCESSORI - INSERTO TUBOLARE XJG.....	65
	ACCESSOIRES - TRAPPE A MEMBRANE.....		ACCESSORI - PORTELLO A MEMBRANA.....	66
	ACCESSOIRES - BASE POUR AVERTISSEUR DE ROTATION XVA.....		ACCESSORI - BASETTA PER SEGNALETORE DI ROTAZIONE XVA.....	67
	ACCESSOIRES - SEMELLE SUPPORT XJS.....		ACCESSORI - SELLA XJS.....	68
	ACCESSOIRES - JOINT FLUXE SUPPLEMENTAIRE.....		ACCESSORI - TENUTA FLUSSATA AGGIUNTIVA.....	69
	ACCESSOIRES - SAS PORTILLON.....		ACCESSORI - BOCCAPORTO.....	70
	ACCESSOIRES - ANNEAUX DE RENFORT.....		ACCESSORI - ANELLI DI RINFORZO.....	71
	OPTIONS - SPIRES RAPIDEMENT EXTRACTIBLES.....		OPZIONI - RAPIDA ESTRAIBILITÀ SPIRE.....	72
	DISPOSITION CONSTRUCTIVE.....		DISPOSIZIONE TRUOGOLI.....	73
	COLISAGE.....		INGOMBRI SPEDIZIONE.....	74
	POIDS MU_P.....		PESI MU_P.....	75
	POIDS MU_E AN.....		PESI MU_E AN.....	76

2	CATALOGUE D'ENTRETIEN	2	CATALOGO DI MANUTENZIONE	
	UTILISATION ET ENTRETIEN.....		USO E MANUTENZIONE.....	M. 4 → 23

3	CATALOGUE PIECES DE RECHANGE	3	CATALOGO RICAMBI	
	PIECES DE RECHANGE.....		PEZZI DI RICAMBIO.....	R. 5
	PIECES DE RECHANGE - VUE GENERALE.....		PEZZI DI RICAMBIO - QUADRO GENERALE.....	6
	PIECES DE RECHANGE.....		PEZZI DI RICAMBIO.....	4
	PIECES DE RECHANGE - SUPPORT D'EXTREMITÉ XSP-XSR.....		PEZZI DI RICAMBIO - SUPPORTO D'ESTREMITÀ XSP-XSR.....	8 → 12
	PIECES DE RECHANGE - ETANCHEITE XUC.....		PEZZI DI RICAMBIO - TENUTA XUC.....	13 → 16
	PIECES DE RECHANGE.....		PEZZI DI RICAMBIO.....	17 → 43

ORDERING SPARE PARTS	ERSATZTEILBESTELLUNG	COMMANDE DE PIECES DE RECHANGE	ORDINAZIONE DEI PEZZI DI RICAMBIO
<p>A) Steel fabricated parts and bearing assemblies Please indicate serial n° of the conveyor applied on each trough section, as well as page and item n° in this catalogue of the part concerned. Also indicate the required quantity of parts taking into consideration the minimum supply given in the price list.</p>	<p>A) Stahlbauteile und Lager-einheiten Folgende Angaben sind hierfür erforderlich: Produktions-Nr. der Schnecke (abzulesen auf jedem Schnecken-teil), Seitenzahl und Position im Katalog sowie die gewünschte Menge (Mindestmenge bitte der Preisliste entnehmen).</p>	<p>A) Pièces en charpente et pailiers Quand vous passez une commande d'une pièce de rechange, nous vous prions de nous communiquer le N° de fabrication que vous trouvez sur chaque section de la vis, le N° de la page et de la position de la pièce dans ce catalogue, ainsi que la quantité désirée en tenant compte du minimum indiqué dans la liste de prix.</p>	<p>A) pezzi di carpenteria e di supporto All'ordine sono da comunicare il N°. matricolare della coclea riportato su ogni spezzone della stessa, il N°. di pagina, il N°. o la lettera di posizione e la descrizione del pezzo nonché la quantità richiesta tenendo conto delle quantità minime riportate nel listino prezzi.</p>
<p>B) Gear reduction units and electric motors Instead of the screw serial n° indicate serial n° of gear reduction unit or of the electric motor and add information requested in paragraph A). Parts not included in price list cannot be supplied. These are: 1) Standard parts if not included in kits. 2) Item numbers in brackets, i.e. single parts included in kits.</p>	<p>B) Getriebeeinheiten und Elektromotoren Anstelle der Produktions-Nr. der Schnecke ist die Produktions-Nr. des Getriebes bzw. des E-Motors anzugeben. Ansonsten sind die unter Punkt A bereits genannten Angaben hinzuzufügen. In der Preisliste nicht aufgeführte Positionen sind nicht lieferbar. Im einzelnen sind dies: 1) Normteile sofern die Montagesätze diese nicht beinhalten, 2) in Klammern gesetzte Positionen bzw. Einzelteile zu den Montagesätzen.</p>	<p>B) Réducteurs et moteurs électriques Au lieu du N° de fabrication de la vis il faut indiquer celui du réducteur ou du moteur. Ensuite ajoutez l'information demandée sous la lettre A). Les pièces qui ne sont pas comprises dans la liste de prix ne peuvent pas être fournies. En particulier ce sont: 1) Les pièces commerciales à normes européennes si pas comprises dans les kits 2) Les positions entre parenthèses, c'est à dire les composants des kits.</p>	<p>B) Testate motrici e motori elettrici Al posto del N°. matricolare della coclea indicare quello della testata motrice o del motore elettrico. Quindi aggiungere le altre informazioni richieste sotto la lettera A). I prezzi non compresi nel listino prezzi non possono essere forniti. In particolare sono: 1) pezzi a norme se non compresi nei kits 2) numeri di posizione tra parentesi o, cioè singoli componenti dei kits.</p>
<p>Check minimum supply before making an order.</p>	<p>Vor der Auftragserteilung die in der Preisliste aufgeführten Mindestmengen für die jeweiligen Artikel prüfen.</p>	<p>Avant le passage d'une commande vérifier les quantités minimum dans la liste de prix.</p>	<p>Prima di passare un ordine verificare la quantità minima indicata nel listino prezzi.</p>
<p>General Supply Conditions are valid.</p>	<p>Es gelten die Allgemeinen Verkaufs- und Lieferbedingungen.</p>	<p>Nos Conditions Générales de Vente sont valables.</p>	<p>Sono valide le ns. Condizioni Generali di vendita.</p>

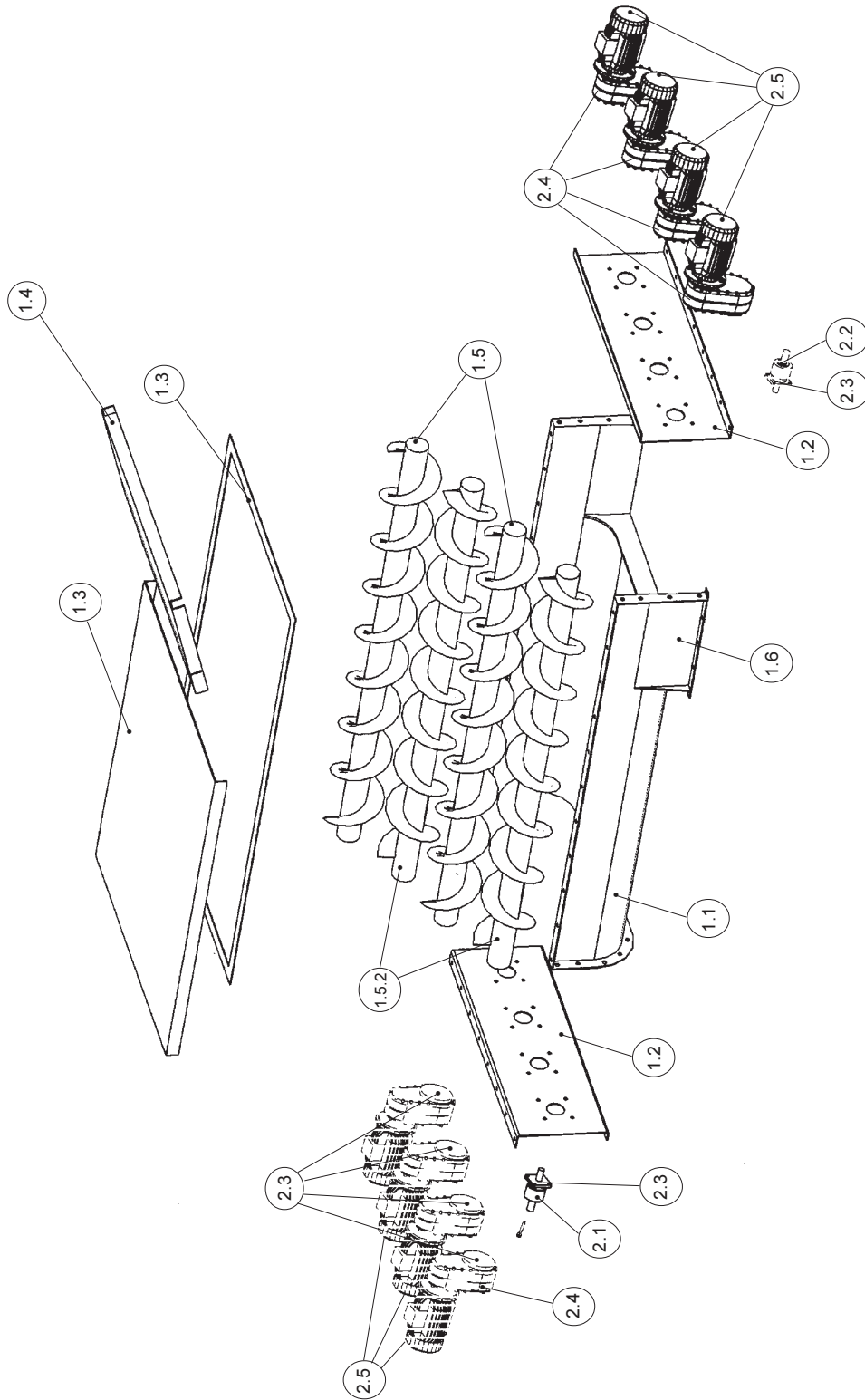

Item Pos.	Description	Benennung	Désignation	Denominazione	Code
1	STRUCTURAL COMPONENTS	STAHLBAUTEILE	PARTIE STRUCTURE	PARTE CARPENTERIA	
1.1	Trough	Trog	Auge	Truogolo	
1.2	End plate	Endschild	Porte-palier	Portasupporto	
1.3	Cover + Gasket	Deckel + Dichtung	Couvercle + Joint	Coperchio + Guarnizione	
1.4	Inspection hatch	Inspektionsklappe	Trappe de visite	Portello ispezionabile	
1.5	Right screw	Rechter Wendel	Spire Droite	Spira dx	
1.5.2	Left Screw	Linker Wendel	Spire Gauche	Spira sx	
1.6	Outlet	Auslauf	Bouche de sortie	Bocca uscita	
2	MECHANICAL PARTS	MECHANISCHE TEILE	PARTIE MECANIQUE	PARTE MECCANICA	
2.1	Inlet end bearing	Einlaufendlager	Palier côté chargement	Supporto lato carico	
2.2	Outlet end bearing	Auslaufendlager	Palier côté déchargement	Supporto lato scarico	
2.3	Sealing	Dichtung	Etanchéité	Tenuta	
2.4	Gear reducer	Getriebe	Réducteur	Testata Motrice	
2.5	Electric motor	Elektromotor	Moteur électrique	Motore elettrico	

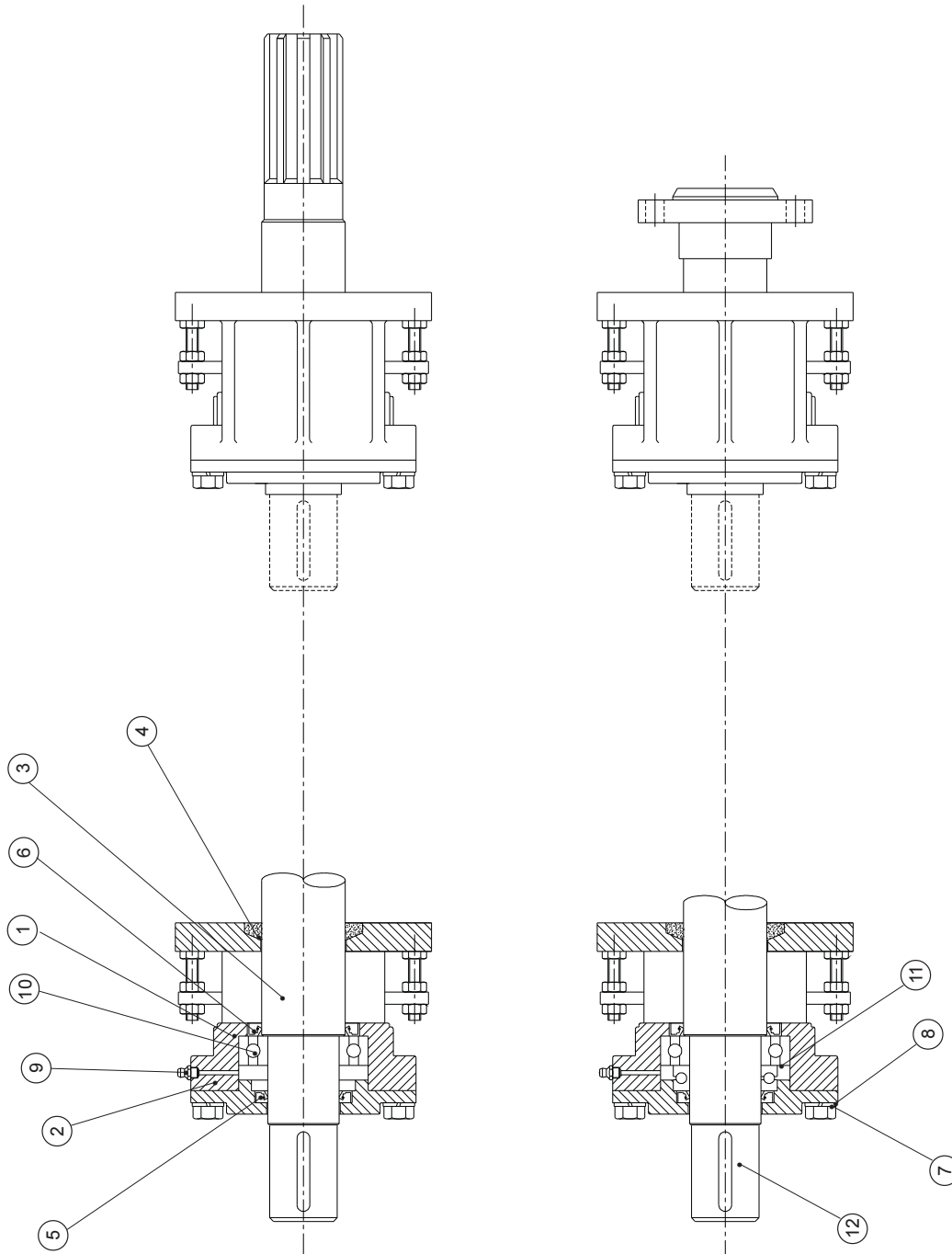

		XSP025..*1 XSR025..*1					
Item Pos.	Quant. Menge	Code	Standards Normen Normes Norme	Description	Benennung	Désignation	Descrizione
1	1	20.90.101.1/A		Casing	Gehäuse	Corps	Corpo
2	1	20.90.341.1/A		Cover	Deckel	Couvercle	Coperchio
3	1	1*		Splined end shaft	Vielkeilwelle	Arbre cannelé	Albero brocciato
4	1	20.98.9251/A		Felt packing	Filzring	Feutre	Feltro
5	1	BA42x30x7		Rotary shaft seal	Wellendichtring	Joint d'étanchéité	Anello tenuta
6	1	BA50x35x8		Rotary shaft seal	Wellendichtring	Joint d'étanchéité	Anello tenuta
7	4	(M 8 x 20)	DIN 588	Hexagonal bolt	Sechskantschr.	VTH	V.T.E.
8	4	(M 8)	DIN 125-A	Washer	Unterlegscheibe	Rondelle	Rosetta
9	1	(B4 M 10 x 1)		Grease nipple	Schmiernippel	Graisseur	Ingrassatore
10	1	(6206)(30x62x10)		Bearing	Wälzlager	Roulement	Cuscinetto
11*	1		(51106)(30x47x11)	Bearing	Wälzlager	Roulement	Cuscinetto
12	1		8x7x36 DIN6885	Parallel key	Paßfeder	Clavette	Linguetta

Pos. 11*: only for - nur für XSP055BZ1 - XSP055BV1
 seulement pour - solo per

	Type	Shaft Welle Arbre Albero
1*	XSP025AZ1 XSP025BZ1	20940011A
	XSP025AV1 XSP025BV1	20948761A
	XSR025AZ1 XSR025BV1	20941281A
	XSR025AV1 XSR025BV1	20941151A

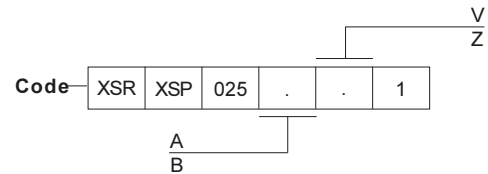

		XSP035..*1 XSR035..*1					
Item Pos.	Quant. Menge	Code	Standards Normen Normes Norme	Description	Benennung	Désignation	Descrizione
1	1	20.90.102.1/A		Casing	Gehäuse	Corps	Corpo
2	1	20.90.342.1/A		Cover	Deckel	Couvercle	Coperchio
3	1	1*		Splined end shaft	Vielkeilwelle	Arbre cannelé	Albero brocciato
4	1	20.98.805.1/A		Felt packing	Filzring	Feutre	Feltro
5	1	BA52x40x7		Rotary shaft seal	Wellendichtring	Joint d'étanchéité	Anello tenuta
6	1	BA60x45x10		Rotary shaft seal	Wellendichtring	Joint d'étanchéité	Anello tenuta
7	4	(M 10 x 23)	DIN 588	Hexagonal bolt	Sechskantschr.	VTH	V.T.E.
8	4	(M 10)	DIN 125-A	Washer	Unterlegscheibe	Rondelle	Rosetta
9	1	(B4 M 10 x 1)		Grease nipple	Schmiernippel	Graisseur	Ingrassatore
10	1	(6208)(40x80x18)		Bearing	Wälzlager	Roulement	Cuscinetto
11*	1		(51108)(40x60x13)	Bearing	Wälzlager	Roulement	Cuscinetto
12	1		10x8x50 DIN6885	Parallel key	Paßfeder	Clavette	Linguetta

Pos. 11*: only for - nur für XSP035BZ1 - XSP035BV1
 seulement pour - solo per

	Type	Shaft Welle Arbre Albero
1*	XSP035AZ1 XSP035BZ1	20940021A
	XSP035AV1 XSP035BV1	20948771A
	XSR035AZ1 XSR035BV1	20941291A
	XSR035AV1 XSR035BV1	20941161A

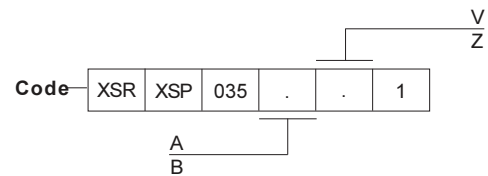

		XSP045.**1 XSR045.**1					
Item Pos.	Quant. Menge	Code	Standards Normen Normes Norme	Description	Benennung	Désignation	Descrizione
1	1	20.90.103.1/A		Casing	Gehäuse	Corps	Corpo
2	1	20.90.343.1/A		Cover	Deckel	Couvercle	Coperchio
3	1	1*		Splined end shaft	Vielkeiwelle	Arbre cannelé	Albero brocciato
4	1	20.98.949.1/A		Felt packing	Filzring	Feutre	Feltro
5	1	BASL 65x50x8		Rotary shaft seal	Wellendichtring	Joint d'étanchéité	Anello tenuta
6	1	BA72x55x10		Rotary shaft seal	Wellendichtring	Joint d'étanchéité	Anello tenuta
7	4	(M 10 x 30)	DIN 588	Hexagonal bolt	Sechskantschr.	VTH	V.T.E.
8	4	(M 10)	DIN 125-A	Washer	Unterlegscheibe	Rondelle	Rosetta
9	1	(B4 M 10 x 1)		Grease nipple	Schmiernippel	Graisseur	Ingrassatore
10	1	(6210)(50x30x20)		Bearing	Wälzlager	Roulement	Cuscinetto
11*	1		(51110)(50x70x14)	Bearing	Wälzlager	Roulement	Cuscinetto
12	1		10x8x50 DIN6885	Parallel key	Paßfeder	Clavette	Linguetta

Pos. 11*: only for - nur für XSP045BZ1 - XSP045BV1
seulement pour - solo per

	Type	Shaft Welle Arbre Albero
1*	XSP045AZ1 XSP045BZ1	20940031A
	XSP045AV1 XSP045BV1	20948781A
	XSR045AZ1 XSR045BV1	20941301A
	XSR045AV1 XSR045BV1	20941171A

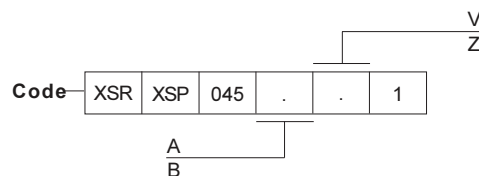

		XSP055.**1 XSR055.**1					
Item Pos.	Quant. Menge	Code	Standards Normen Normes Norme	Description	Benennung	Désignation	Descrizione
1	1	20.90.104.1/A		Casing	Gehäuse	Corps	Corpo
2	1	20.90.344.1/A		Cover	Deckel	Couvercle	Coperchio
3	1	1*		Splined end shaft	Vielkeiwelle	Arbre cannelé	Albero brocciato
4	1	20.98.810.1/A		Felt packing	Filzring	Feutre	Feltro
5	1	BA80x60x10		Rotary shaft seal	Wellendichtring	Joint d'étanchéité	Anello tenuta
6	1	BA90x70x10		Rotary shaft seal	Wellendichtring	Joint d'étanchéité	Anello tenuta
7	4	(M 12 x 30)	DIN 588	Hexagonal bolt	Sechskantschr.	VTH	V.T.E.
8	4	(M 12)	DIN 125-A	Washer	Unterlegscheibe	Rondelle	Rosetta
9	1	(B4 M 10 x 1)		Grease nipple	Schmiernippel	Graisseur	Ingrassatore
10	1	(6212)(60x110x22)		Bearing	Wälzlager	Roulement	Cuscinetto
11*	1		(51112)(60x85x17)	Bearing	Wälzlager	Roulement	Cuscinetto
12	1		10x8x50 DIN6885	Parallel key	Paßfeder	Clavette	Linguetta

Pos. 11*: only for - nur für XSP035BZ1 - XSP035BV1
seulement pour - solo per

	Type	Shaft Welle Arbre Albero
1*	XSP055AZ1 XSP055BZ1	20940041A
	XSP055AV1 XSP055BV1	20948791A
	XSR055AZ1 XSR055BV1	20941311A
	XSR055AV1 XSR055BV1	20941181A

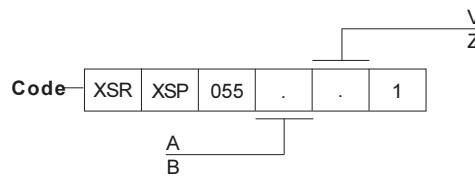

XSP065..1 XSR065..1							
Item Pos.	Quant. Menge	Code	Standards Normen Normes Norme	Description	Benennung	Désignation	Descrizione
1	1	20.90.105.1/A		Casing	Gehäuse	Corps	Corpo
2	1	20.90.345.1/A		Cover	Deckel	Couvercle	Coperchio
3	1	1*		Splined end shaft	Vielkeilwelle	Arbre cannelé	Albero brocciato
4	1	20.98.930.1/A		Felt packing	Filzring	Feutre	Feltro
5	1	BASL90x70x10		Rotary shaft seal	Wellendichtring	Joint d'étanchéité	Anello tenuta
6	1	BA100x80x10		Rotary shaft seal	Wellendichtring	Joint d'étanchéité	Anello tenuta
7	4		DIN 588	Hexagonal bolt	Sechskantschr.	VTH	V.T.E.
8	4		DIN 125-A	Washer	Unterlegscheibe	Rondelle	Rosetta
9	1	(B4 M 10 x 1)		Grease nipple	Schmiernippel	Graisseur	Ingrassatore
10	1		(6214)(70x125x24)	Bearing	Wälzlager	Roulement	Cuscinetto
11*	1		(51114)(70x95x18)	Bearing	Wälzlager	Roulement	Cuscinetto
12	1		10x8x50 DIN6885	Parallel key	Paßfeder	Clavette	Linguetta

Pos. 11*: only for - *nur für* **XSP065BZ1 - XSP065BV1**
 seulement pour - *solo per*

1*	Type	Shaft Welle Arbre Albero
	XSP065AZ1 XSP065BZ1	20940051A
XSP065AV1 XSP065BV1	20948801A	
XSR065AZ1 XSR065BZ1	20941321A	
XSR065AV1 XSR065BV1	20941191A	

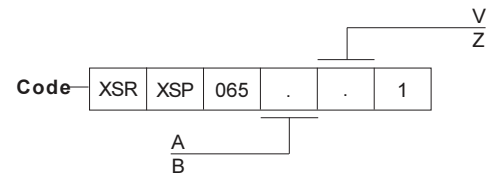

XSP080..1 XSR080..1							
Item Pos.	Quant. Menge	Code	Standards Normen Normes Norme	Description	Benennung	Désignation	Descrizione
1	1	20.90.107.1/A		Casing	Gehäuse	Corps	Corpo
2	1	20.90.347.1/A		Cover	Deckel	Couvercle	Coperchio
3	1	1*		Splined end shaft	Vielkeilwelle	Arbre cannelé	Albero brocciato
4	1	20.98.930.1/A		Felt packing	Filzring	Feutre	Feltro
5	1	BAX110x90x12		Rotary shaft seal	Wellendichtring	Joint d'étanchéité	Anello tenuta
6	1	BAX120x100x12		Rotary shaft seal	Wellendichtring	Joint d'étanchéité	Anello tenuta
7	4		DIN 588	Hexagonal bolt	Sechskantschr.	VTH	V.T.E.
8	4		DIN 125-A	Washer	Unterlegscheibe	Rondelle	Rosetta
9	1	(B4 M10 x 1)		Grease nipple	Schmiernippel	Graisseur	Ingrassatore
10	1		(6218)(90x160x30)	Bearing	Wälzlager	Roulement	Cuscinetto
11*	1		(51118)(90x120x22)	Bearing	Wälzlager	Roulement	Cuscinetto
12	1		10x8x50 DIN6885	Parallel key	Paßfeder	Clavette	Linguetta

Pos. 11*: only for - *nur für* **XSP080BZ1 - XSP080BV1**
 seulement pour - *solo per*

1*	Type	Shaft Welle Arbre Albero
	XSP080AZ1 XSP080BZ1	20940071A
XSP080AV1 XSP080BV1	20948821A	
XSR080AZ1 XSR080BZ1	20941341A	
XSR080AV1 XSR080BV1	20941211A	

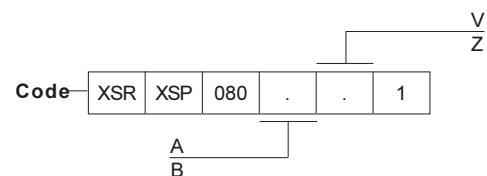

XSP090.**1 XSR090.**1							
Item Pos.	Quant. Menge	Code	Standards Normen Normes Norme	Description	Benennung	Désignation	Descrizione
1	1	20.90.108.1/A		Casing	Gehäuse	Corps	Corpo
2	1	20.90.348.1/A		Cover	Deckel	Couvercle	Coperchio
3	1	1*		Splined end shaft	Vielkeilwelle	Arbre cannelé	Albero brocciato
4	1	20.98.930.1/A		Felt packing	Filzring	Feutre	Feltro
5	1	BA120x100x12		Rotary shaft seal	Wellendichtring	Joint d'étanchéité	Anello tenuta
6	1	BA130x110x12		Rotary shaft seal	Wellendichtring	Joint d'étanchéité	Anello tenuta
7	4		DIN 588	Hexagonal bolt	Sechskantschr.	VTH	V.T.E.
8	4		DIN 125-A	Washer	Unterlegscheibe	Rondelle	Rosetta
9	1	(B4 M 10 x 1)		Grease nipple	Schmiernippel	Graisseur	Ingrassatore
10	1		(6220)(100x180x34)	Bearing	Wälzlager	Roulement	Cuscinetto
11*	1		(51120)(100x135x25)	Bearing	Wälzlager	Roulement	Cuscinetto
12	1		10x8x50 DIN6885	Parallel key	Paßfeder	Clavette	Linguetta

Pos. 11*: only for - nur für XSP090BZ1 - XSP090BV1
 seulement pour - solo per

1*	Type	Shaft Welle Arbre Albero
	XSP090AZ1 XSP090BZ1	20940081A
XSP090AV1 XSP090BV1	20948831A	
XSR090AZ1 XSR090BZ1	20941351A	
XSR090AV1 XSR090BV1	20941221A	

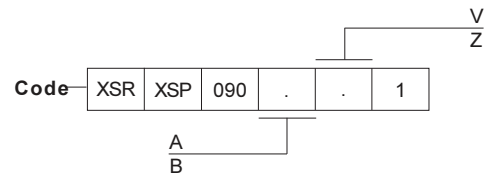

XSR100.**1							
Item Pos.	Quant. Menge	Code	Standards Normen Normes Norme	Description	Benennung	Désignation	Descrizione
1	1	20.90.109.1/A		Casing	Gehäuse	Corps	Corpo
2	1	20.90.349.1/A		Cover	Deckel	Couvercle	Coperchio
3	1	1*		Splined end shaft	Vielkeilwelle	Arbre cannelé	Albero brocciato
4	1	20.98.930.1/A		Felt packing	Filzring	Feutre	Feltro
5	1	BAX130x110x12		Rotary shaft seal	Wellendichtring	Joint d'étanchéité	Anello tenuta
6	1	BAX150x125x12		Rotary shaft seal	Wellendichtring	Joint d'étanchéité	Anello tenuta
7	4		DIN 588	Hexagonal bolt	Sechskantschr.	VTH	V.T.E.
8	4		DIN 125-A	Washer	Unterlegscheibe	Rondelle	Rosetta
9	1	(B4 M10 x 1)		Grease nipple	Schmiernippel	Graisseur	Ingrassatore
10	1		(6222)(110x200x38)	Bearing	Wälzlager	Roulement	Cuscinetto
11*	1		(51122)(100x145x25)	Bearing	Wälzlager	Roulement	Cuscinetto
12	1		10x8x50 DIN6885	Parallel key	Paßfeder	Clavette	Linguetta

Pos. 11*: only for - nur für XSP100BZ1 - XSP100BV1
 seulement pour - solo per

1*	Type	Shaft Welle Arbre Albero
	XSR100AZ1 XSR100BZ1	20941361A
XSR100AV1 XSR100BV1	20941231A	

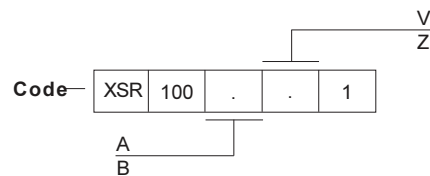

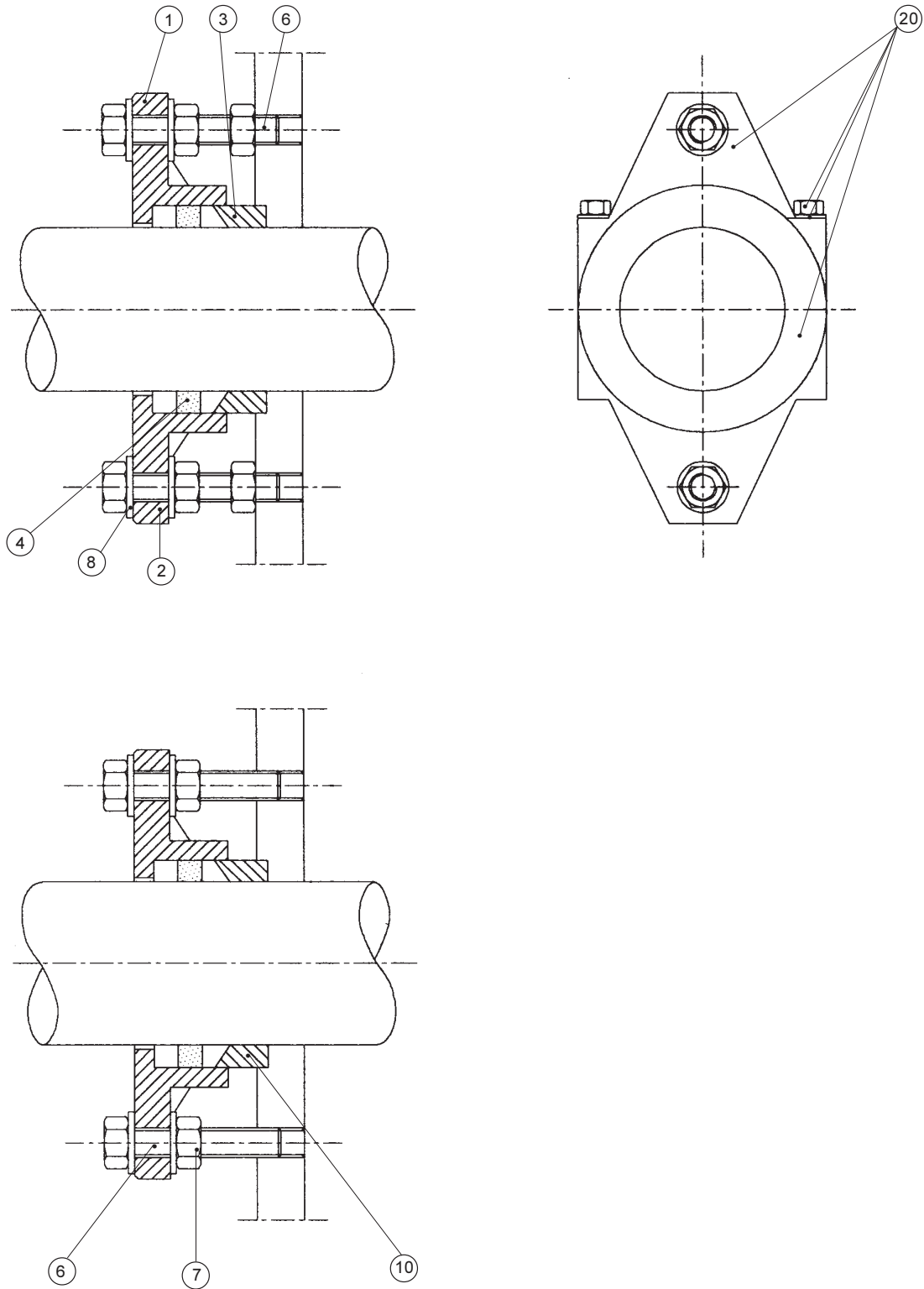



WAM®

MU - BU

- SPARE PARTS
- ERSATZLEIKATALOG
- PIECES DE RECHANGE
- PEZZI DI RICAMBIO

XUC SHAFT SEALING
WELLENABDICHTUNG XUC
ETANCHEITE XUC
TENUTA XUC

12.04



WA.01520 R. 14

Sealing / Wellenab. Etanchéité / Tenuta	For / Für Pour / Per	Sealing / Wellenab. Etanch. / Tenuta	For / Für Pour / Per	Sealing / Wellenab. Etanch. / Tenuta	For / Für Pour / Per
XUC 030 . 1	R 21	XUC 045 . 1	XSP035....	XUC 060 . 1	R 27
XUC 035 . 1	XSP025....	XUC 050 . 1	R25....	XUC 070 . 1	XSP055....
XUC 040 . 1	R23....	XUC 055 . 1	XSP045....		

* for / für
pour / per

XUC03061 3 Felt packings / Filzringe / Feutres / Feltri

030-035-040-045-050-055-060-070

Code XUC 1

B-C-D

Item Pos.	Quant. Menge	Standards Normen Normes Norme	Description	Benennung	Désignation	Descrizione	Code XUC030..1
3	1		Spacer	Distanring	Entretoise	Distanziale	20985281A
4	3		Packing	Packung	Garniture à tresse	Baderna	** (30 x 8 x 46)
5	2	DIN 933	Hexagonal socket screw	Innensechskantschraube	VTCHI	VTCEI	(M6 x 35)
6	2		Threaded bar	Gewindestange	Barre filetée	Barra filettata	20683321B
7	6	DIN 934	Hexagonal nut	Sechskantmutter	Ecrou six pans	Dado esagonale	(M 8)
8	6	DIN 125 A	Washer	Unterlegscheibe	Rondelle	Rosetta	(M 8)
9	2	DIN 7980	Spring washer	Sprengring	Rondelle plate	Rosetta grower	(M 6)
10	1		Seal	Dichtung	Joint	Guarnizione	20991661A
20	1		Packing gland (complete)	Stopfbuchsensbrille komplett	Porte garniture complet	Portabadera completo	16741861A

Item Pos.	Quant. Menge	Standards Normen Normes Norme	Description	Benennung	Désignation	Descrizione	Code XUC035..1
3	1		Spacer	Distanring	Entretoise	Distanziale	20985291A
4	3		Packing	Packung	Garniture à tresse	Baderna	** (35 x 8 x 50)
5	2	DIN 933	Hexagonal socket screw	Innensechskantschraube	VTCHI	VTCEI	(M6 x 35)
6	2		Threaded bar	Gewindestange	Barre filetée	Barra filettata	20683321B
7	6	DIN 934	Hexagonal nut	Sechskantmutter	Ecrou six pans	Dado esagonale	(M 8)
8	6	DIN 125 A	Washer	Unterlegscheibe	Rondelle	Rosetta	(M 8)
9	2	DIN 7980	Spring washer	Sprengring	Rondelle plate	Rosetta grower	(M 6)
10	1		Seal	Dichtung	Joint	Guarnizione	20991051A
20	1		Packing gland (complete)	Stopfbuchsensbrille komplett	Porte garniture complet	Portabadera completo	16741871B

Item Pos.	Quant. Menge	Standards Normen Normes Norme	Description	Benennung	Désignation	Descrizione	Code XUC040..1
3	1		Spacer	Distanring	Entretoise	Distanziale	20985301A
4	3		Packing	Packung	Garniture à tresse	Baderna	** (40 x 8 x 56)
5	2	DIN 933	VTCEI	Innensechskantschraube	VTCHI	VTCEI	(M6 x 40)
6	2		Threaded bar	Gewindestange	Barre filetée	Barra filettata	20683321B
7	6	DIN 934	Hexagonal nut	Sechskantmutter	Ecrou six pans	Dado esagonale	(M 8)
8	6	DIN 125 A	Washer	Unterlegscheibe	Rondelle	Rosetta	(M 8)
9	2	DIN 7980	Spring washer	Sprengring	Rondelle plate	Rosetta grower	(M 6)
10	1		Seal	Dichtung	Joint	Guarnizione	20991731A
20	1		Packing gland (complete)	Stopfbuchsensbrille komplett	Porte garniture complet	Portabadera completo	16741881A



WAM®

MU - BU

- SPARE PARTS XUC SHAFT SEALING
- ERSATZLEIKATALOG WELLENABDICHTUNG XUC
- PIECES DE RECHANGE ETANCHEITE XUC
- PEZZI DI RICAMBIO TENUTA XUC

12.04



WA.01520.R. 15

Sealing / Wellenab. Etanchéité / Tenuta	For / Für Pour / Per	Sealing / Wellenab. Etanch. / Tenuta	For / Für Pour / Per	Code	XUC	1
XUC 030 . 1	R 21	XUC 045 . 1	XSP035....	XUC 060 . 1	030-035-040-045-050-055-060-070			
XUC 035 . 1	XSP025....	XUC 050 . 1	R25....	XUC 070 . 1	B-C-D			
XUC 040 . 1	R23....	XUC 055 . 1	XSP045....	* for / für pour / per XUC03061 3 Felt packings / Filzringe / Feutres / Feltri				

Item Pos.	Quant. Menge	Standards Normen Normes Norme	Description	Benennung	Désignation	Description	Code XUC045..1
3	1		Spacer	Distanring	Entretoise	Distanziale	20985311A
4	3		Packing	Packing	Garniture à tresse	Baderna	**/(45 x 8 x 61)
5	2	DIN 933	Hexagonal socket screw	Innensechskantschraube	VTCHI	VTCEI	(M6 x 40)
6	2		Threaded bar	Gewindestange	Barre filetée	Barra filettata	20683321B
7	6	DIN 934	Hexagonal nut	Sechskantmutter	Ecrou six pans	Dado esagonale	(M 8)
8	6	DIN 125 A	Washer	Unterlegscheibe	Rondelle	Rosetta	(M 8)
9	2	DIN 7980	Spring washer	Sprengring	Rondelle plate	Rosetta grower	(M 6)
10	1		Seal	Dichtung	Joint	Guarnizione	20991061A
20	1		Packing gland (complete)	Stopfbuchsenbrille komplett	Porte garniture complet	Portabaterna completo	16741891A

Item Pos.	Quant. Menge	Standards Normen Normes Norme	Description	Benennung	Désignation	Description	Code XUC050..1
3	1		Spacer	Distanring	Entretoise	Distanziale	20985321A
4	3		Packing	Packing	Garniture à tresse	Baderna	**/(50x 10 x70)
5	2	DIN 933	Hexagonal socket screw	Innensechskantschraube	VTCHI	VTCEI	(M8 x 45)
6	2		Threaded bar	Gewindestange	Barre filetée	Barra filettata	20683331B
7	6	DIN 934	Hexagonal nut	Sechskantmutter	Ecrou six pans	Dado esagonale	(M 10)
8	6	DIN 125 A	Washer	Unterlegscheibe	Rondelle	Rosetta	(M 10)
9	2	DIN 7980	Spring washer	Sprengring	Rondelle plate	Rosetta grower	(M 8)
10	1		Seal	Dichtung	Joint	Guarnizione	20991071A
20	1		Packing gland (complete)	Stopfbuchsenbrille komplett	Porte garniture complet	Portabaterna completo	16741901B

Item Pos.	Quant. Menge	Standards Normen Normes Norme	Description	Benennung	Désignation	Description	Code XUC055..1
3	1		Spacer	Distanring	Entretoise	Distanziale	20985331A
4	3		Packing	Packing	Garniture à tresse	Baderna	**/(55 x10 x75)
5	2	DIN 933	Hexagonal socket screw	Innensechskantschraube	VTCHI	VTCEI	(M8 x 50)
6	2		Threaded bar	Gewindestange	Barre filetée	Barra filettata	20683321B
7	6	DIN 934	Hexagonal nut	Sechskantmutter	Ecrou six pans	Dado esagonale	(M 10)
8	6	DIN 125 A	Washer	Unterlegscheibe	Rondelle	Rosetta	(M 10)
9	2	DIN 7980	Spring washer	Sprengring	Rondelle plate	Rosetta grower	(M 10)
10	1		Seal	Dichtung	Joint	Guarnizione	20991071A
20	1		Packing gland (complete)	Stopfbuchsenbrille komplett	Porte garniture complet	Portabaterna completo	16741911B

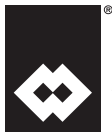

WAM®

MU - BU

- SPARE PARTS

XUC SHAFT SEALING

- ERSATZLEIKATALOG

WELLENABDICHTUNG XUC

- PIECES DE RECHANGE

ETANCHEITE XUC

- PEZZI DI RICAMBIO

TENUTA XUC

12.04

3

WA.01520 R. 16

Sealing / Wellenab. Etanchéité / Tenuta	For / Für Pour / Per	Sealing / Wellenab. Etanch. / Tenuta	For / Für Pour / Per	Sealing / Wellenab. Etanch. / Tenuta	For / Für Pour / Per
XUC 030 . 1	R 21	XUC 045 . 1	XSP035	XUC 060 . 1	R 27
XUC 035 . 1	XSP025	XUC 050 . 1	R 25	XUC 070 . 1	XSP055
XUC 040 . 1	R 23	XUC 055 . 1	XSP045		

Code XUC 1

030-035-040-045-050-055-060-070 B-C-D

* for / für XUC03061 3 Felt packings / Filzringe / Feutres / Feltri
pour / per XUC03061 3 Felt packings / Filzringe / Feutres / Feltri

Item Pos.	Quant. Menge	Standards Normen Norme	Description	Benennung	Désignation	Descrizione	Code XUC060..1
3	1		Spacer	Distanzring	Entretoise	Distanziale	20985341A
4	3		Packing	Packing	Garniture à tresse	Baderna	** (60 x10 x80)
5	2	DIN 933	Hexagonal socket screw	Innensechskantschraube	VTCHI	VTCEI	(M8 x 50)
6	2		Threaded bar	Gewindestange	Barre fileté	Barra filettata	20683331B
7	6	DIN 934	Hexagonal nut	Sechskantmutter	Ecrou six pans	Dado esagonale	(M 10)
8	6	DIN 125 A	Washer	Unterlegscheibe	Rondelle	Rosetta	(M 10)
9	2	DIN 7980	Spring washer	Sprengring	Rondelle plate	Rosetta grower	(M 8)
10	1		Seal	Dichtung	Joint	Guarnizione	20991591A
20	1		Packing gland (complete)	Stopfbuchsenbrille komplett	Porte garniture complet	Portabaderna completo	16741921B

Item Pos.	Quant. Menge	Standards Normen Norme	Description	Benennung	Désignation	Descrizione	Code XUC070..1
3	1		Spacer	Distanzring	Entretoise	Distanziale	20985351A
4	3		Packing	Packing	Garniture à tresse	Baderna	** (70x10 x90)
5	2	DIN 933	Hexagonal socket screw	Innensechskantschraube	VTCHI	VTCEI	(M8 x 50)
6	2		Threaded bar	Gewindestange	Barre fileté	Barra filettata	20683331B
7	6	DIN 934	Hexagonal nut	Sechskantmutter	Ecrou six pans	Dado esagonale	(M 10)
8	6	DIN 125 A	Washer	Unterlegscheibe	Rondelle	Rosetta	(M 10)
9	2	DIN 7980	Spring washer	Sprengring	Rondelle plate	Rosetta grower	(M 8)
10	1		Seal	Dichtung	Joint	Guarnizione	20991081A
20	1		Packing gland (complete)	Stopfbuchsenbrille komplett	Porte garniture complet	Portabaderna completo	16741931A

**	Packing type - <i>Packung Typ</i> Type de garniture à tresse - <i>Tipo di baderna</i>		
	B1	C1	D1
XUC030..	20988212A	20988211A	2510020350
XUC035..	20988232A	20988231A	2510020350
XUC040..	20988242A	20988241A	2510020350
XUC045..	20988282A	20988281A	2510020350
XUC050..	20988292A	20988291A	2510020360
XUC055..	20988332A	20988331A	2510020360
XUC060..	20988342A	20988341A	2510020360
XUC070..	20988342A	20988341A	2510020360

Gear reduction head	series	S 21
Getriebe	Serien	
Tête motrice	série	
Testata motrice	serie	

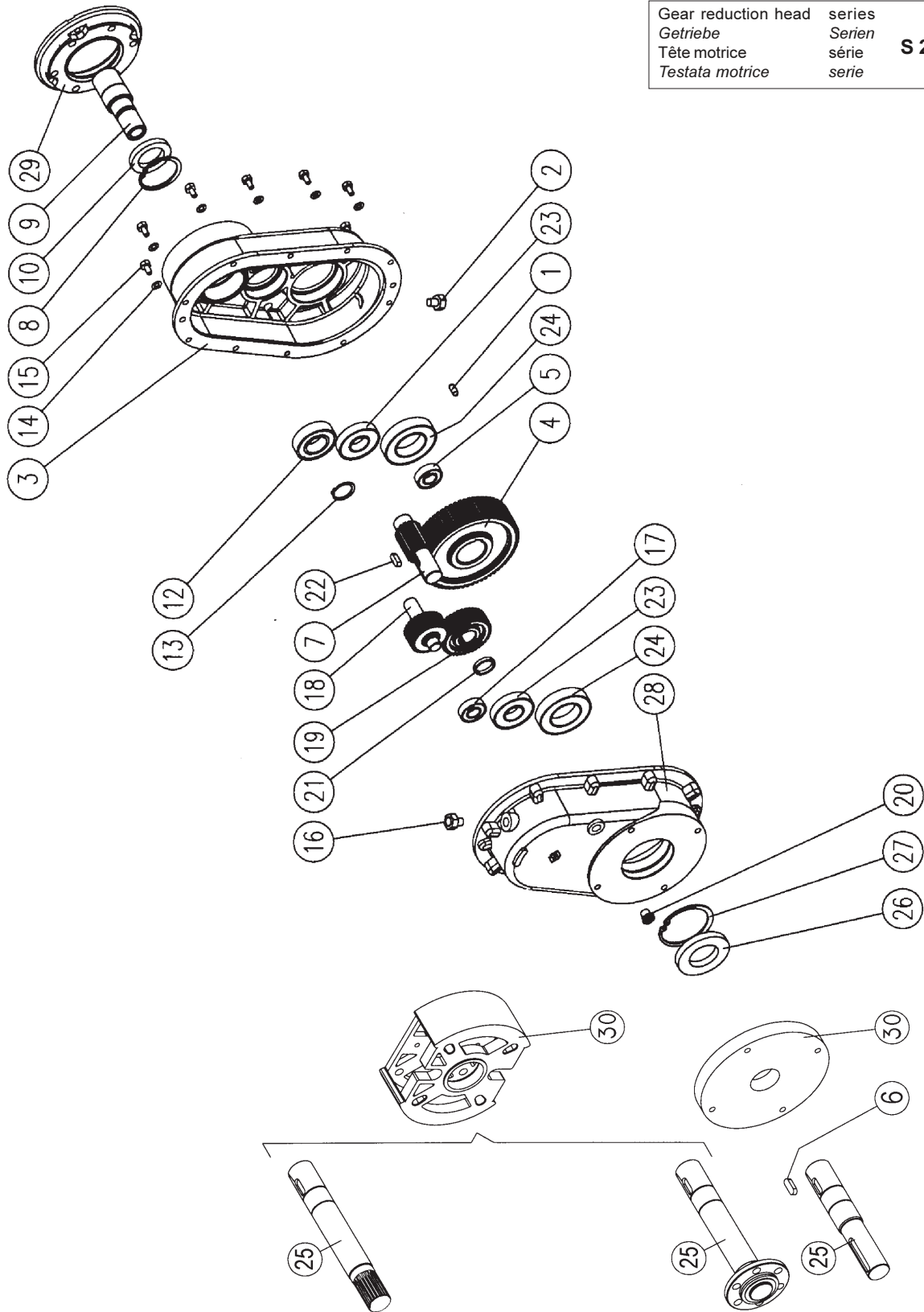

Gear reduction head series
Getriebe Serien
Tête motrice série
Testata motrice serie

S 21
Code
S 21

Ratio/Unters./Réd./Rapporto

 GR. Motor size
Motore

 Type Output - Abtrieb
Sortie - Uscita

Item Quant. Pos. Menge	Standards Normen Normes Norme	DESCRIPTION	BENENNUNG	DESIGNATION	DENOMINAZIONE	Code
		Sealing kit	Dichtungssatz	Kit étanchéité	Kit tenuta	13009900A
26	DIN 3760 NB	Rotary shaft seal	Weilendichtring	Joint d'étanchéité	Anello di tenuta	(62x30x7)
10	DIN 3760 NB	Rotary shaft seal	Weilendichtring	Joint d'étanchéité	Anello di tenuta	(72x45x8)
1	DIN 7	Cylindrical pin	Zylinderstift	Goupille cylindrique	Spina cilindrica	(Ø 10x20)
		Bearing kit	Lagersatz	Kit roulements	Kit cuscinetti	13009880A
12		Radial bearing	Radialrollenkugellager	Roulement radial	Cuscinetto radiale	(6207)(35x72x17)
23		Radial bearing	Radialrollenkugellager	Roulement radial	Cuscinetto radiale	(6203)(17x40x12)
24		Radial bearing	Radialrollenkugellager	Roulement radial	Cuscinetto radiale	(6206)(30x62x16)
17		Radial bearing	Radialrollenkugellager	Roulement radial	Cuscinetto radiale	(6202)(15x35x11)
		Retaining ring kit	Satz Sicherungsringe	Kit circlip "Seeger"	Kit seeger	13009890A
13	DIN 471	Retaining ring for shaft	Seegerring für Welle	Seeger pour arbre	Seeger per albero	(Ø 35)
27	DIN 472	Retaining ring for bore	Seegerring für Bohrung	Seeger pour perçage	Seeger per foro	(Ø 62)
8	DIN 472	Retaining ring for bore	Seegerring für Bohrung	Seeger pour perçage	Seeger per foro	(Ø 72)
14	DIN 912	Hexagon bolt	Sechskantschraube	VTH	Vite T.C.E.I	(M 6x25)
15	DIN 125A	Washer	Unterlegscheibe	Rondelle	Rondella bisellata	(M 6)
13	DIN 127B	Elastic washer	Elastische Scheibe	Rondelle élastique	Rosetta elastica	(M 6)
2		Oil outlet plug	Ablassschraube	Bouchon de vidange	Tappo di scarico	(3/8")
		Casing	Gehäuse	Corps réducteur	Corpo riduttore	
3		Input casing	Gehäuse eingangsseite	Corps côté entrée	Corpo lato entrata	20920951A
28		Output casing	Gehäuse abtriebsseite	Corps côté sortie	Corpo lato uscita	20920961A
		Input	Eingang	Entrée	Entrata PAM	
		Motor size 071	Baugrosse 071	Bride moteur 071	Grandeza motore 071	
29		Input flange	Eingangsfansch	Bride entrée	Flangia entrata	20924041A
9		Hollow shaft	Hohlwelle	Embout entrée	Boccola entrata	20970151A
6	DIN 912	Hexagon screw	Innensechskantschraube	Vis	Vite T.C.E.I	(10x50)
4	DIN 912	Hexagon screw	Sechskantschraube	Vis	Vite T.C.E.I	(12x35)
4	DIN 125A	Washer	Unterlegscheibe	Rondelle	Rondelle	(13x24)
4	DIN 127B	Elastic washer	Elastische Scheibe	Rondelle élastique	Rosetta elastica	(M 12)

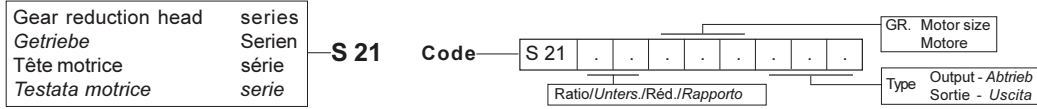

Item Quant. Pos. Menge	Standards Normen Normes Norme	DESCRIPTION	BENENNUNG	DESIGNATION	DENOMINAZIONE	Code
		Input gear kit	Eingang	Entrée	Entrata PAM	
		Motor size 080	Baugröße 080	Bride moteur 080	Grandezza motore 080	20924051A
29	1	Input flange	Eingangsfiansch	Bride entrée	Flangia entrata	
9	1	Hollow shaft	Hohlwelle	Embout entrée	Boccola entrata	20970161A
	6	Hexagonal screw	Innensechskantschraube	Vis	Vite T.C.E.I	(10x50)
	4	Hexagonal screw	Sechskantschraube	Vis	Vite T.C.E.I	(12x35)
	4	Washer	Unterlegscheibe	Rondelle	Rondelle	(13x24)
	4	Elastic washer	Elastische Scheibe	Rondelle élastique	Rondella elastica	(M12)
		Input gear kit	Eingang	Entrée	Entrata PAM	
		Motor size 090	Baugröße 090	Bride moteur 090	Grandezza motore 090	
29	1	Input flange	Eingangsfiansch	Bride entrée	Flangia entrata	20924051A
9	1	Hollow shaft	Hohlwelle	Embout entrée	Boccola entrata	20970171A
	6	Hexagonal screw	Innensechskantschraube	Vis	Vite T.C.E.I	(10x50)
	4	Hexagonal screw	Sechskantschraube	Vis	Vite T.C.E.I	(12x35)
	4	Washer	Unterlegscheibe	Rondelle	Rondelle	(13x24)
	4	Elastic washer	Elastische Scheibe	Rondelle élastique	Rondella elastica	(M12)
		Input gear kit	Eingang	Entrée	Entrata PAM	
		Motor size 100 - 112	Baugröße 100 - 112	Bride moteur 100 - 112	Grandezza motore 100 - 112	
29	1	Input flange	Eingangsfiansch	Bride entrée	Flangia entrata	20924081A
9	1	Hollow shaft	Hohlwelle	Embout entrée	Boccola entrata	20970181A
	6	Hexagonal screw	Innensechskantschraube	Vis	Vite T.C.E.I	(10x50)
	4	Hexagonal screw	Sechskantschraube	Vis	Vite T.C.E.I	(12x35)
	4	Washer	Unterlegscheibe	Rondelle	Rondelle	(13x24)
	4	Elastic washer	Elastische Scheibe	Rondelle élastique	Rondella elastica	(M12)
		Input "C"	Eingang "C"	Entree "C"	Entrata "C"	
9	1	Shaft	Welle	Arbre entrée	Albero entrata	20970511A



WAM®

MU - BU

- SPARE PARTS
- ERSATZLEIKATALOG
- PIÈCES DE RECHANGE
- PEZZI DI RICAMBIO

12.04

3

WA.01520 R. 20

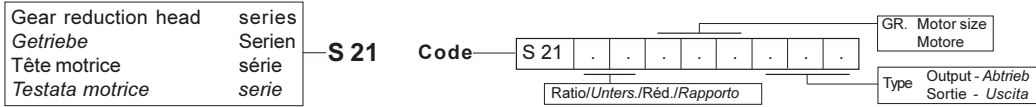

Item Pos.	Quant. Menge	Standards Normen Norme	DESCRIPTION	BENENNUNG	DESIGNATION	DENOMINAZIONE	Code
			Input gear Ratio 1/10	Radsatz Eingangsseite Untersetzung 1:10	Engrainages d'entrée Réduction 1:10	Sottogruppo coppia entrata Rapporto riduttore 1:10	10752630A
18	1		Pinion	Ritzel	Pignon	Pignone	
19	1		Gear wheel	Zahnrad	Roue dentée	Corona	(5x5x16)
22	1	DIN 6885	Parallel key	Passfeder	Clavette	Linguetta	
			Input gear Ratio 1/12	Radsatz eingangsseite Untersetzung 1:12	Engrainages d'entrée Réduction 1:12	Sottogruppo coppia entrata Rapporto riduttore 1:12	10752640A
18	1		Pinion	Ritzel	Pignon	Pignone	
19	1		Gear wheel	Zahnrad	Roue dentée	Corona	
22	1	DIN 6885	Parallel key	Passfeder	Clavette	Linguetta	(5x5x16)
			Input gear Ratio 1/16	Radsatz eingangsseite Untersetzung 1:16	Engrainages d'entrée Réduction 1:16	Sottogruppo coppia entrata Rapporto riduttore 1:16	10752650A
18	1		Pinion	Ritzel	Pignon	Pignone	
19	1		Gear wheel	Zahnrad	Roue dentée	Corona	
22	1	DIN 6885	Parallel key	Passfeder	Clavette	Linguetta	(5x5x16)
			Input gear Ratio 1/20	Radsatz eingangsseite Untersetzung 1:20	Engrainages d'entrée Réduction 1:20	Sottogruppo coppia entrata Rapporto riduttore 1:20	10752660A
18	1		Pinion	Ritzel	Pignon	Pignone	
19	1		Gear wheel	Zahnrad	Roue dentée	Corona	(5x5x16)
22	1	DIN 6885	Parallel key	Passfeder	Clavette	Linguetta	
			Input gear Ratio 1/25	Radsatz eingangsseite Untersetzung 1:25	Engrainages d'entrée Réduction 1:25	Sottogruppo coppia entrata Rapporto riduttore 1:25	10752670A
18	1		Pinion	Ritzel	Pignon	Pignone	
19	1		Gear wheel	Zahnrad	Roue dentée	Corona	(5x5x16)
22	1	DIN 6885	Parallel key	Passfeder	Clavette	Linguetta	
			Input gear Ratio 1/30	Radsatz eingangsseite Untersetzung 1:30	Engrainages d'entrée Réduction 1:30	Sottogruppo coppia entrata Rapporto riduttore 1:30	10752690A
18	1		Pinion	Ritzel	Pignon	Pignone	
19	1		Gear wheel	Zahnrad	Roue dentée	Corona	(5x5x16)
22	1	DIN 6885	Parallel key	Passfeder	Clavette	Linguetta	
			Input gear Ratio 1/30	Radsatz eingangsseite Untersetzung 1:30	Engrainages d'entrée Réduction 1:30	Sottogruppo coppia entrata Rapporto riduttore 1:30	10752690A
18	1		Pinion	Ritzel	Pignon	Pignone	
19	1		Gear wheel	Zahnrad	Roue dentée	Corona	(5x5x16)
22	1	DIN 6885	Parallel key	Passfeder	Clavette	Linguetta	

Gear reduction head series
Getriebe Serien
Tête motrice série
Testata motrice serie

S 21
Code

S 21

Ratio/Unters./Réd./Rapporto

 GR. Motor size
Motore

 Type Output - Abtrieb
Sortie - Uscita

Item Pos.	Quant. Menge	Standards Normen Norme	DESCRIPTION	BENENNUNG	DESIGNATION	DENOMINAZIONE	Code
			Input gear Ratio 1/40	Radsatz Eingangsseite Untersetzung 1:40	Engrainages d'entrée Reduction 1:40	Sottogruppo coppia entrata Rapporto riduttore 1:40	10752710A
18	1		Pinion	Ritzel	Pignon	Pignone	
19	1		Gear wheel	Zahnrad	Roue dentée	Corona	
22	1	DIN 6885	Parallel key	Passfeder	Clavette	Linguetta (5x5x16)	10752680A
7	1		Output gear 1:5-1:25	Radsatz Abtriebsseite 1:5-1:25	Engrainages de sortie 1:5-1:25	Sottogruppo coppia uscita 1:5-1:25	10752680A
4	1		Pinion	Ritzel	Pignon	Pignone	
4	1		Gear wheel	Zahnrad	Roue dentée	Corona	
6	1	DIN 6885	Parallel key	Passfeder	Clavette	Linguetta (8x7x22)	10752700A
7	1		Output gear 1:30-1:40	Radsatz Abtriebsseite 1:30-1:40	Engrainages de sortie 1:30-1:40	Sottogruppo coppia uscita 1:30-1:40	10752700A
4	1		Pinion	Ritzel	Pignon	Pignone	
4	1		Gear wheel	Zahnrad	Roue dentée	Corona	
6	1	DIN 6885	Parallel key	Passfeder	Clavette	Linguetta (8x7)	
			Output A 3	Ausgang A 3	Sortie A 3	Uscita A 3	
30	1		Output flange	Ausgangsflansch	Bride sortie	Flangia uscita	20923011B
25	1		Output shaft	Abtriebswelle	Arbre sortie	Albero uscita	20947551A
	4	DIN 912	Hexagonal socket bolt	Innensechskantschraube	VHT	Vite T.C.E.I. (10x35)	
	4	DIN 933	Hexagonal bolt	Sechskantschraube	VHT	Vite T.E. (10x35)	
	4	DIN 125A	Washer	Unterlegscheibe	Rondelle	Rondella (M 10)	
		DIN 127B	Elastic washer	Elastische Scheibe	Rondelle élastique	Rosetta elastica (M 10)	

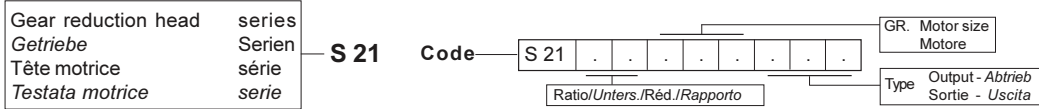

Item Pos.	Quant. Menge	Standards Normen Norme	DESCRIPTION	BENENNUNG	DESIGNATION	DENOMINAZIONE	Code
			Output A 4	Ausgang A 4	Sortie A 4	Uscita A 4	
30	1		Output flange	Ausgangsflansch	Bride sortie	Flangia uscita	20923111B
25	1		Output shaft	Abtriebswelle	Arbre sortie	Albero uscita	20947561A
	4	DIN 912	Hexagonal socket bolt	Innensechskantschraube	VHT	Vite T.C.E.I.	(10x35)
	4	DIN 933	Hexagonal bolt	Sechskantschraube	VHT	Vite T.E.	(10x35)
	4	DIN 125A	Washer	Unterlegscheibe	Rondelle	Rondella	(M 10)
	4	DIN 127B	Elastic washer	Elastische Scheibe	Rondelle élastique	Rosetta elastica	(M 10)
			Felt ring	Filzring	Joint garniture	Anello di feltro	20989241A
			Output A 6	Ausgang A 6	Sortie A 6	Uscita A 6	
30	1		Output flange	Ausgangsflansch	Bride sortie	Flangia uscita	20923111B
25	1		Output shaft	Abtriebswelle	Arbre sortie	Albero uscita	20947561A
	4	DIN 912	Hexagonal socket bolt	Innensechskantschraube	VHT	Vite T.C.E.I.	(10x35)
	4	DIN 933	Hexagonal bolt	Sechskantschraube	VHT	Vite T.E.	(10x35)
	4	DIN 125A	Washer	Unterlegscheibe	Rondelle	Rondella	(M 10)
	4	DIN 127B	Elastic washer	Elastische Scheibe	Rondelle élastique	Rosetta elastica	(M 10)
			Felt ring	Filzring	Joint garniture	Anello di feltro	20989241A
			Output K	Ausgang K	Sortie K	Uscita K	
30	1		Output flange	Ausgangsflansch	Bride sortie	Flangia uscita	20924291A
25	1		Output shaft	Abtriebswelle	Arbre sortie	Albero uscita	20947601A
	4	DIN 912	Hexagonal socket bolt	Innensechskantschraube	VHT	Vite T.C.E.I.	(10x35)
	4	DIN 933	Hexagonal bolt	Sechskantschraube	VHT	Vite T.E.	(10x35)
	4	DIN 125A	Washer	Unterlegscheibe	Rondelle	Rondella	(M 10)
	4	DIN 127B	Elastic washer	Elastische Scheibe	Rondelle élastique	Rosetta elastica	(M 10)

Gear reduction head	series	S 23
Getriebe	Serien	
Tête motrice	série	
Testata motrice	serie	

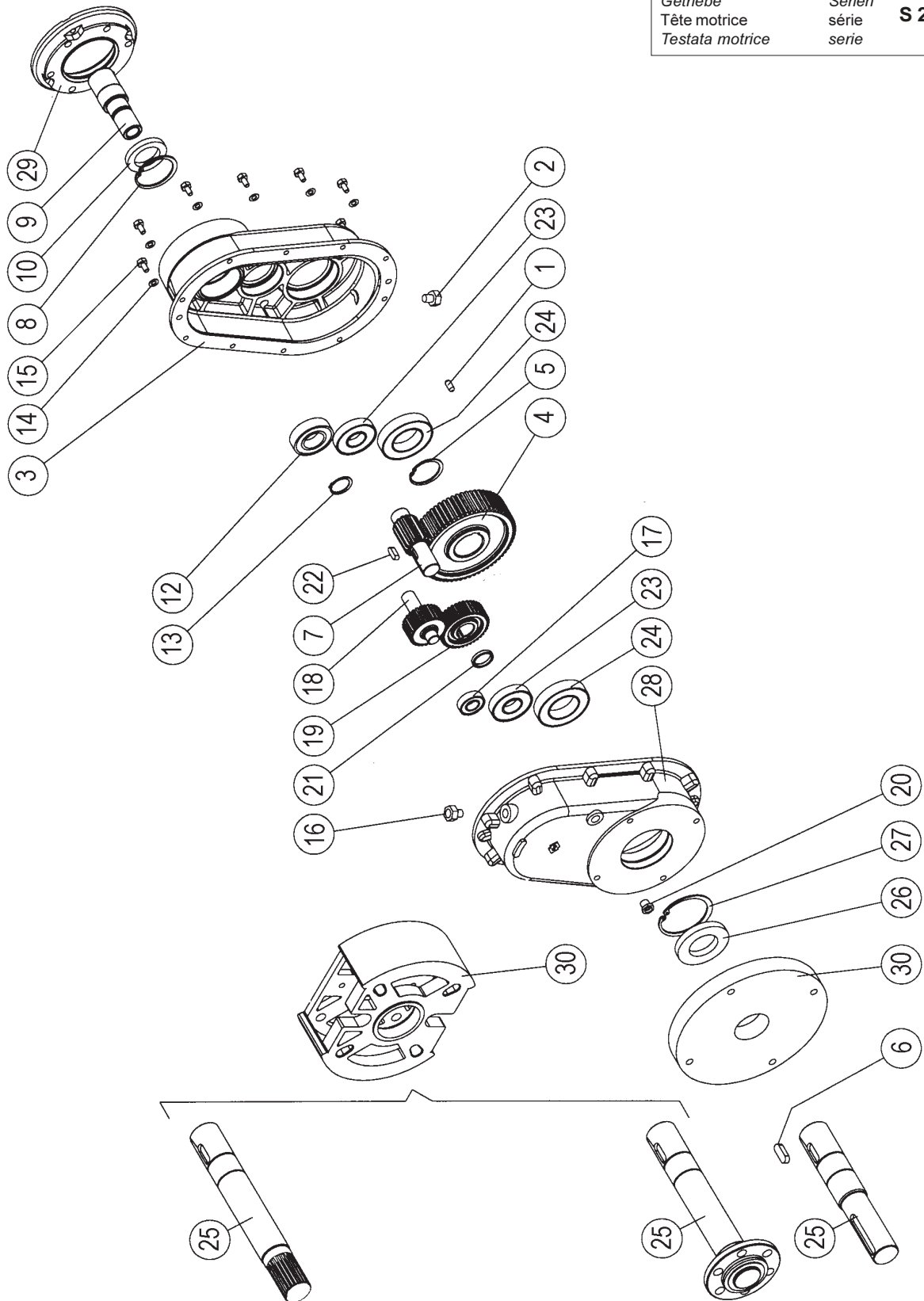

Gear reduction head series
Getriebe Serien
Tête motrice série
Testata motrice serie

S 23

Code

S 23

Ratio/Unters./Réd./Rapporto

 GR. Motor size
Motore

 Type Output - Abtrieb
Sortie - Uscita

Item Pos.	Quant. Menge	Standards Normen Normes Norme	Description	Benennung	Designation	Denominazione	Code
			Sealing kit 90/100/112	Dichtungssatz 90/100/112	Kit étanchéité 90/100/112	Kit tenute 30/100/112	13009500A
26	1	DIN 3760 NB	Rotary shaft seal	Weilendichtring	Joint d'étanchéité	Anello di tenuta	(80x40x10)
10	1	DIN 3760 NB	Rotary shaft seal	Weilendichtring	Joint d'étanchéité	Anello di tenuta	(80x45x10)
1	2	DIN 7	Cylindrical pin	Zylinderstift	Goupille cylindrique	Spina cilindrica	(10x20)
			Sealing kit 132	Dichtungssatz 132	Kit étanchéité 132	Kit tenute 132	13009510A
26	1	DIN 3760 NB	Rotary shaft seal	Weilendichtring	Joint d'étanchéité	Anello di tenuta	(80x40x10)
10	1	DIN 3760 NB	Rotary shaft seal	Weilendichtring	Joint d'étanchéité	Anello di tenuta	(80x55x10)
1	2	DIN 7	Cylindrical pin	Zylinderstift	Goupille cylindrique	Spina cilindrica	(10x20)
			Sealing kit 160	Dichtungssatz 160	Kit étanchéité 160	Kit tenute 160	13009520A
26	1	DIN 3760 NB	Rotary shaft seal	Weilendichtring	Joint d'étanchéité	Anello di tenuta	(80x40x10)
10	1	DIN 3760 NB	Rotary shaft seal	Weilendichtring	Joint d'étanchéité	Anello di tenuta	(80x60x80)
1	2	DIN 7	Cylindrical pin	Zylinderstift	Goupille cylindrique	Spina cilindrica	(10x20)
			Bearing kit	Lagersatz	Kit roulements	Kit cuscinetti	12009480A
12	1		Radial bearing	Radialrollenkugellager	Roulement radial	Cuscinetto radiale	(6206) (30x62x16)
23	2		Radial bearing	Radialrollenkugellager	Roulement radial	Cuscinetto radiale	(6304) (20x52x15)
24	2		Radial bearing	Radialrollenkugellager	Roulement radial	Cuscinetto radiale	(6208) (40x80x18)
17	1		Radial bearing	Radialrollenkugellager	Roulement radial	Cuscinetto radiale	(6303) (17x47x14)
			Retaining ring kit	Satz sicherungsringe	Kit circlip "seeger"	Kit seeger	13009490A
13	1	DIN 471	Retaining ring for shaft	Seegerring für Welle	Seeger pour arbre	Seeger per albero	(Ø30)
27	1	DIN 472	Retaining ring for bore	Seegerring für Bohrung	Seeger pour perçage	Seeger per foro	(Ø62)
8	1	DIN 472	Retaining ring for bore	Seegerring für Bohrung	Seeger pour perçage	Seeger per foro	(Ø80)
14	10	DIN 912	Hexagon socket bolt	Innensechskantschraube	VTH	Vite T.C.E.I.	(M8x25)
15	20	DIN 125A	Washer	Unterlegscheibe	Rondelle	Rondella bisellata	(M8)
			Elastic washer	Elastische Scheibe	Rondelle élastique	Rosetta elastica	(M8)
			Oil plug kit	Ölschraubensatz	Kit lubrification	Kit tappi lubrificazione	13008330A
16	1		Breather plug	Entlüftungsschraube	Bouchon reniflard	Tappo di carico e sfiato	(3/8")
2	1		Oil outlet plug	Ablassschraube	Bouchon de vidange	Tappo di scarico	(3/8")
20	1		Oil level plug	Ölastandschraube	Bouchon de niveau	Indicatore di livello a vista	(3/8")
			Casing	Gehäuse	Corps réducteur	Corpo riduttore	
3	1		Input casing	Gehäuse Eingangsseite	Corps côté entrée	Corpo lato entrata	20920901A
28	1		Output casing	Gehäuse Atrißsseite	Corps côté sortie	Corpo lato uscita	20920911A

Gear reduction head series
Getriebe Serien
Tête motrice série
Testata motrice serie

S 23
Code

S 23

Ratio/Unters./Réd./Rapporto

 GR. Motor size
Motore

 Type Output - Abtrieb
Sortie - Uscita

Item Pos.	Standards Quant. Normen Menge Normes Norme	Description	Benennung	Designation	Denominazione	Code
		Input	Eingang	Entrée	Entrata PAM	
		Motor size 080	Baugrosse 080	Bride moteur 080	Grandezza motore 080	
29	1	Input flange	Eingangsfansch	Bride entrée	Flangia entrata	20924061A
9	1	Hollow shaft	Hohlwelle	Embout entrée	Boccola entrata	209QDOR1A
	6	Hexagon socket bolt	Innensechskantschraube	Vis	Vite T.C.E.I.	(M10x50)
	4	Hexagon socket bolt	Innensechskantschraube	Vis	Vite T.C.E.I.	(M10x30)
	4	Washer	Unterlegscheibe	Rondelle	Rondelle	(M10)
	4	Elastic washer	Elastische Scheibe	Rondelle élastique	Rondella elastica	(M10)
		Input	Eingang	Entrée	Entrata PAM	
		Motor size 090	Baugrosse 090	Bride moteur 090	Grandezza motore 090	
29	1	Input flange	Eingangsfansch	Bride entrée	Flangia entrata	20924061A
9	1	Hollow shaft	Hohlwelle	Embout entrée	Boccola entrata	209QDOK1A
	6	Hexagon socket bolt	Innensechskantschraube	Vis	Vite T.C.E.I.	(M10x50)
	4	Hexagon socket bolt	Innensechskantschraube	Vis	Vite T.C.E.I.	(M10x30)
	4	Washer	Unterlegscheibe	Rondelle	Rondelle	(M10)
	4	Elastic washer	Elastische Scheibe	Rondelle élastique	Rondella elastica	(M10)
		Input	Eingang	Entrée	Entrata PAM	
		Motor size 100 - 112	Baugrosse 100 - 112	Bride moteur 100 - 112	Grandezza motore 100-112	
29	1	Input flange	Eingangsfansch	Bride entrée	Flangia entrata	20924091A
9	1	Hollow shaft	Hohlwelle	Embout entrée	Boccola entrata	209QDOC1A
	6	Hexagon socket bolt	Innensechskantschraube	Vis	Vite T.C.E.I.	(M10x50)
	4	Hexagon socket bolt	Innensechskantschraube	Vis	Vite T.C.E.I.	(M10x30)
	4	Washer	Unterlegscheibe	Rondelle	Rondelle	(M10)
	4	Elastic washer	Elastische Scheibe	Rondelle élastique	Rondella elastica	(M10)
		Input	Eingang	Entrée	Entrata PAM	
		Motor size 132	Baugrosse 132	Bride moteur 132	Grandezza motore 132	
29	1	Input flange	Eingangsfansch	Bride entrée	Flangia entrata	20924121A
9	1	Hollow shaft	Hohlwelle	Embout entrée	Boccola entrata	209QDOM1A
	6	Hexagon socket bolt	Innensechskantschraube	Vis	Vite T.C.E.I.	(M10x50)
	4	Hexagon socket bolt	Innensechskantschraube	Vis	Vite T.C.E.I.	(M12x35)
	4	Washer	Unterlegscheibe	Rondelle	Rondelle	(M10)
	4	Elastic washer	Elastische Scheibe	Rondelle élastique	Rondella elastica	(M12)

Gear reduction head	series
Getriebe	Serien
Tête motrice	série
Testata motrice	serie

S 23
Code

S 23
Ratio/Unters./Réd./Rapporto									

GR. Motor size	
Motore	

Type	Output - Abtrieb
	Sortie - Uscita

Item Pos.	Quant. Menge	Standards Normen Normes Norme	Description	Benennung	Designation	Denominazione	Code
			Input	Eingang	Entrée	Entrata PAM	
			Motor size 160	Baugrosse 160	Bride moteur 160	Grandezza motore 160	20924431A
29	1		Input flange	Eingangsfansch	Bride entrée	Flangia entrata	209QDON1A
9	1		Hollow shaft	Hohlwelle	Embout entrée	Boccola entrata	(M10x50)
	6	DIN 912	Hexagon socket bolt	Innensechskantschraube	Vis	Vite T.C.E.I.	(M12x35)
	4	DIN 912	Hexagon socket bolt	Innensechskantschraube	Vis	Vite T.C.E.I.	(M10)
	4	DIN 125 A	Washer	Unterlegscheibe	Rondelle	Rondelle	(M12)
	4	DIN 127 B	Elastic washer	Elastische Scheibe	Rondelle élastique	Rondella elastica	
			Input "C"	Eingang "C"	Entrée "C"	Entrata "C"	
9	1	DIN 6885	Shaft	Welle	Abre entrée	Albero entrata	209QDOP1A
			Input gears	Radsatz Eingangsseite	Engrainages d'entrée	Sottogruppo coppia entrata	10752510A
			Ratio 1:10	Untersetzung 1:10	Réduction 1:10	Rapporto riduttore 1:10	
18	1		Pinion	Ritzel	Pignon	Pignone	
19	1		Gear wheel	Zahnrad	Roue dentée	Corona	(6X6x20)
22	1	DIN 6885	Parallel key	Passfeder	Clavette	Linguetta	
			Input gear kit	Radsatz Eingangsseite	Engrainages d'entrée	Sottogruppo coppia entrata	10752520A
			Ratio 1/12	Untersetzung 1:12	Réduction 1:12	Rapporto riduttore 1:12	
18	1		Pinion	Ritzel	Pignon	Pignone	
19	1		Gear wheel	Zahnrad	Roue dentée	Corona	(6X6x20)
22	1	DIN 6885	Parallel key	Passfeder	Clavette	Linguetta	
			Input gear	Radsatz Eingangsseite	Engrainages d'entrée	Sottogruppo coppia entrata	10752530A
			Ratio 1/16	Untersetzung 1:16	Réduction 1:16	Rapporto riduttore 1:16	
18	1		Pinion	Ritzel	Pignon	Pignone	
19	1		Gear wheel	Zahnrad	Roue dentée	Corona	(6x6x20)
22	1	DIN 6885	Parallel key	Passfeder	Clavette	Linguetta	
			Input gear	Radsatz Eingangsseite	Engrainages d'entrée	Sottogruppo coppia entrata	10752540A
			Ratio 1/20	Untersetzung 1:20	Réduction 1:20	Rapporto riduttore 1:20	
18	1		Pinion	Ritzel	Pignon	Pignone	
19	1		Gear wheel	Zahnrad	Roue dentée	Corona	
22	1		Parallel key	Passfeder	Clavette	Linguetta	

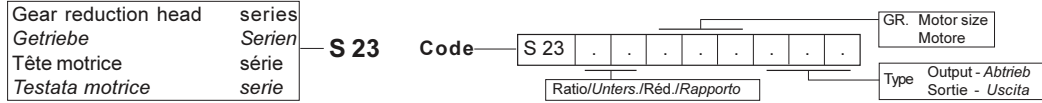

Item Quant. Pos. Menge	Standards Normen Normes Norme	Description	Benennung	Designation	Denominazione	Code
		Input gear	Radsatz Eingangsseite	Engrainages d'entrée	Sottogruppo coppia entrata	10752550A
		Ratio 1/25	Untersetzung 1:25	Réduction 1:25	Rapporto riduttore 1:25	
18	1	Pinion	Ritzel	Pignon	Pignone	
19	1	Gear wheel	Zahnrad	Roue dentée	Corona	
22	1	Parallel key	Passfeder	Clavette	Linguetta	
		Output gear	Radsatz Arbtreibsseite	Engrainages de sortie	Sottogruppo coppia uscita	10752440A
		Ratio 1/5 -1/25	Untersetzung 1:5 -1:25	Réduction 1:5 -1:25	Rapporto riduttore 1:5 -1:25	
18	1	Pinion	Ritzel	Pignon	Pignone	
19	1	Gear wheel	Zahnrad	Roue dentée	Corona	
22	1	Parallel key	Passfeder	Clavette	Linguetta	(12x8x32)
		Spacer	Distanzring	Entretoise	Distanziale	20984891A
		Spacer	Distanzring	Entretoise	Distanziale	20984881A
		Output gear	Radsatz Arbtreibsseite	Engrainages de sortie	Sottogruppo coppia uscita	10752450A
		Ratio 1/30 -1/40	Untersetzung 1:30 -1:40	Réduction 1:30 -1:40	Rapporto riduttore - 1:30 - 1:40	
18	1	Pinion	Ritzel	Pignon	Pignone	
19	1	Gear wheel	Zahnrad	Roue dentée	Corona	
22	1	Parallel key	Passfeder	Clavette	Linguetta	(12x8x32)
		Spacer	Distanzring	Entretoise	Distanziale	20984891A
		Spacer	Distanzring	Entretoise	Distanziale	20984881A
		Input gear	Radsatz Eingangsseite	Engrainages d'entrée	Sottogruppo coppia entrata	10752550A
		Ratio 1/30	Untersetzung 1:30	Réduction 1:30	Rapporto riduttore 1:30	
18	1	Pinion	Ritzel	Pignon	Pignone	
19	1	Gear wheel	Zahnrad	Roue dentée	Corona	
22	1	Parallel key	Passfeder	Clavette	Linguetta	10752560A
		Input gear	Radsatz Eingangsseite	Engrainages d'entrée	Sottogruppo coppia entrata	
		Ratio 1/40	Untersetzung 1:40	Réduction 1:40	Rapporto riduttore 1:40	
18	1	Pinion	Ritzel	Pignon	Pignone	
19	1	Gear wheel	Zahnrad	Roue dentée	Corona	
22	1	Parallel key	Passfeder	Clavette	Linguetta	(6X6x20)

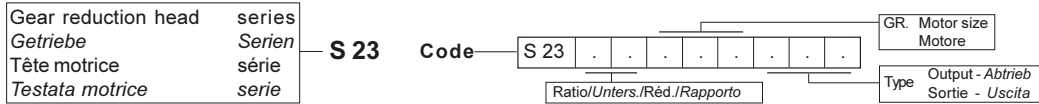

Item Pos.	Quant. Menge	Standards Normen Normes Norme	Description	Benennung	Designation	Denominazione	Code
			Output A3	Ausgang A3	Sortie A3	Uscita A3	
30	1		Output flange	Ausgangsflansch	Bride sortie	Flangia uscita	20923021A
25	1		Output shaft	Abtriebswelle	Arbre sortie	Albero uscita	20947441A
	4	DIN 933	Hexagon bolt	Sechskantschraube	VHT	Vite T.E.	(M10x150)
	4	DIN 127B	Elastic washer	Elastische Scheibe	Rondelle élastique	Rosetta elastica	(M10)
	4	DIN 125A	Washer	Scheibe	Rondelle	Rondella bisellata	(M10)
	1		Felt ring	Filzing	Joint garniture	Anello di feltro	20989231A
			Output A4	Ausgang A4	Sortie A4	Uscita A4	
30	1		Output flange	Ausgangsflansch	Bride sortie	Flangia uscita	20924171B
25	1		Output shaft	Abtriebswelle	Arbre sortie	Albero uscita	20947461A
	4	DIN 933	Hexagon bolt	Sechskantschraube	VHT	Vite T.E.	(M10x150)
	4	DIN 127B	Elastic washer	Elastische Scheibe	Rondelle élastique	Rosetta elastica	(M10)
	4	DIN 125A	Washer	Scheibe	Rondelle	Rondella bisellata	(M10)
	1		Felt ring	Filzing	Joint garniture	Anello di feltro	20989231A
			Output A6	Ausgang A6	Sortie A6	Uscita A6	
30	1		Output flange	Ausgangsflansch	Bride sortie	Flangia uscita	20924171B
25	1		Output shaft	Abtriebswelle	Arbre sortie	Albero uscita	20947471A
	4	DIN 933	Hexagon bolt	Sechskantschraube	VHT	Vite T.E.	(M10x150)
	4	DIN 127B	Elastic washer	Elastische Scheibe	Rondelle élastique	Rosetta elastica	(M10)
	4	DIN 125A	Washer	Scheibe	Rondelle	Rondella bisellata	(M10)
	1		Felt ring	Filzing	Joint garniture	Anello di feltro	20989231A
			Output K	Ausgang K	Sortie K	Uscita K	
30	1		Output flange	Ausgangsflansch	Bride sortie	Flangia uscita	20924301A
25	1		Output shaft	Abtriebswelle	Arbre sortie	Albero uscita	20947351A
	4	DIN 933	Hexagon bolt	Sechskantschraube	VHT	Vite T.E.	(M10x150)
	4	DIN 127B	Elastic washer	Elastische Scheibe	Rondelle élastique	Rosetta elastica	(M10)
	4	DIN 125A	Washer	Scheibe	Rondelle	Rondella bisellata	(M10)
	1		Hexagon socket bolt	Innensechskantschraube	VHT	Vite T.C.EI.	(M12x2,5)
	1		Hexagon nut	Sechskantmutter	Écrou hexagon	Dado esagonale	(M10)
	1		Parallel key	Passfeder	Clavette	Linguetta	(M10x8x70)

Gear reduction head	series	S 25
Getriebe	Serien	
Tête motrice	série	
Testata motrice	serie	

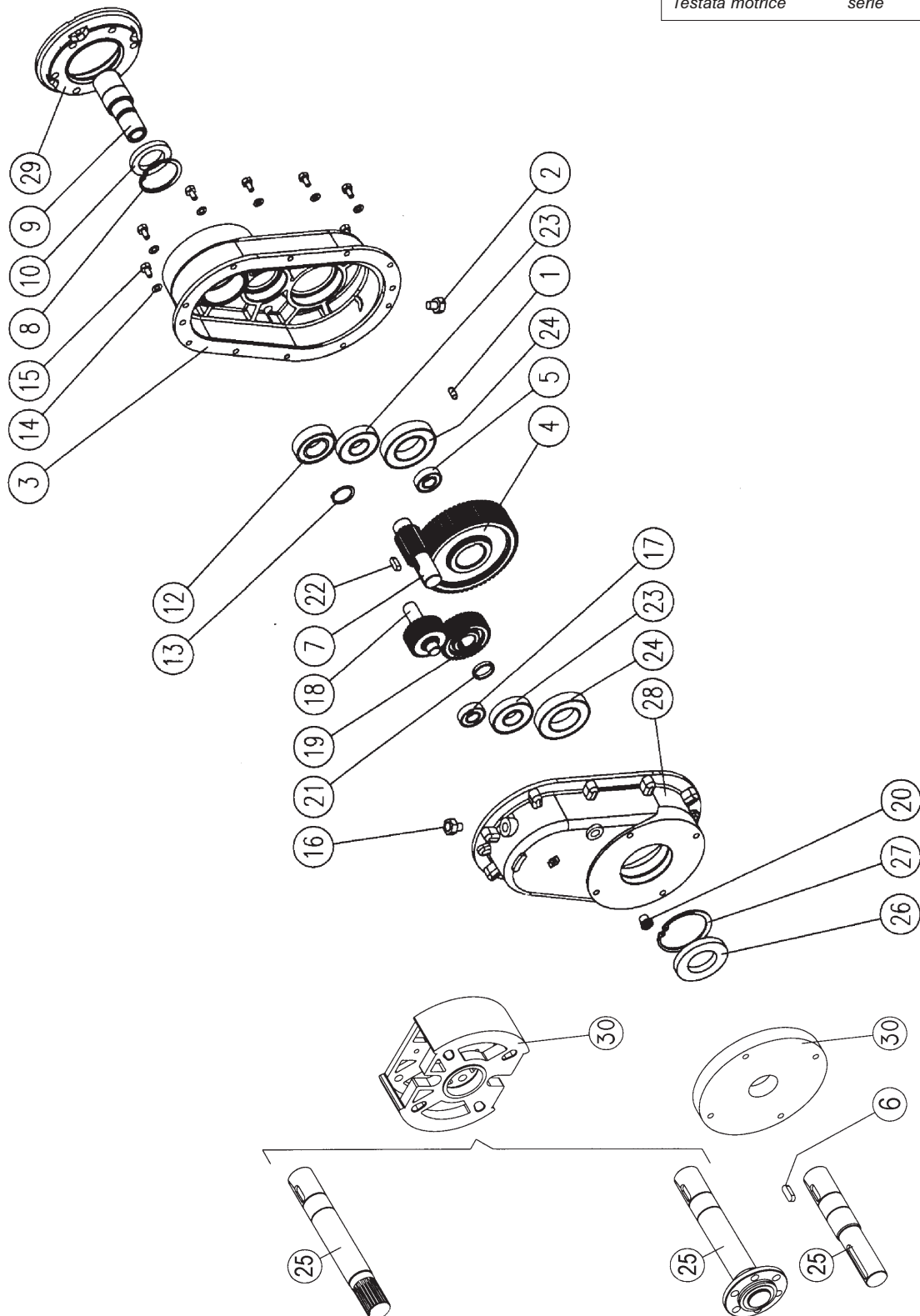

Gear reduction head series
 Getriebe Serien
 Tête motrice série
 Testata motrice serie

S 25

Code

S 25

Ratio/Unters./Red./Rapporto

Type Output - Abtrieb
 Sortie - Uscita

Item Pos.	Quant. Menge	Standards Normen Normes Norme	DESCRIPTION	BENENNUNG	DESIGNATION	DENOMINAZIONE	Code
26	1	DIN 3760 NB	Sealing kit 90/110/112 Rotary shaft seal	Dichtungssatz 90/110/112 Wellendichtring	Kit étanchéité 90/110/112 Joint d'étanchéité	Kit tenuta 90/110/112 Anello di tenuta	13009180A (90x50x10)
10	1	DIN 3760 NB	Rotary shaft seal	Wellendichtring	Joint d'étanchéité	Anello di tenuta	(80x45x10)
1	2	DIN 7	Cylindrical pin	Zylinderstift	Goupille cylindrique	Spina cilindrica	(10x20)
26	1	DIN 3760 NB	Sealing kit GR 132 Rotary shaft seal	Dichtungssatz GR 132 Wellendichtring	Kit étanchéité GR 132 Joint d'étanchéité	Kit tenuta GR 132 Anello di tenuta	13009190A (90x50x10)
10	1	DIN 3760 NB	Rotary shaft seal	Wellendichtring	Joint d'étanchéité	Anello di tenuta	(80x55x10)
1	2	DIN 7	Cylindrical pin	Zylinderstift	Goupille cylindrique	Spina cilindrica	(10x20)
26	1	DIN 3760 NB	Sealing kit GR 160 Rotary shaft seal	Dichtungssatz GR 160 Wellendichtring	Kit étanchéité GR 160 Joint d'étanchéité	Kit tenuta GR 160 Anello di tenuta	13008310A (90x50x10)
10	1	DIN 3760 NB	Rotary shaft seal	Wellendichtring	Joint d'étanchéité	Anello di tenuta	(80x60x8)
1	2	DIN 7	Cylindrical pin	Zylinderstift	Goupille cylindrique	Spina cilindrica	(10x20)
26	1	DIN 3760 NB	Sealing kit GR 180 Rotary shaft seal	Dichtungssatz GR 180 Wellendichtring	Kit étanchéité GR 180 Joint d'étanchéité	Kit tenuta GR 180 Anello di tenuta	13009200A (90x50x10)
10	1	DIN 3760 NB	Rotary shaft seal	Wellendichtring	Joint d'étanchéité	Anello di tenuta	(80x64x8)
1	2	DIN 7	Cylindrical pin	Zylinderstift	Goupille cylindrique	Spina cilindrica	(10x20)
12	1		Bearing kit Radial bearing	Lagersatz Radialrollenkugellager	Kit roulements Roulement radial	Kit cuscinetti Cuscinetto radiale	13008300A 6307 (35x80x21)
23	2		Radial bearing	Radialrollenkugellager	Roulement radial	Cuscinetto radiale	6306 (30x72x19)
24	2		Radial bearing	Radialrollenkugellager	Roulement radial	Cuscinetto radiale	6210 (50x90x20)
17	1		Radial bearing	Radialrollenkugellager	Roulement radial	Cuscinetto radiale	6304 (20x52x15)
13	1	DIN 471	Retaining ring kit Retaining ring for shaft	Satz Sicherungsringe Seegerring für Welle	Kit circlip "Seeger" Seeger pour arbre	Kit seeger Seeger per albero	13008320A (Ø35)
27	2	DIN 472	Retaining ring for bore	Seegerring für Bohrung	Seeger pour perçage	Seeger per foro	(Ø80)
8	1	DIN 472	Retaining ring for bore	Seegerring für Bohrung	Seeger pour perçage	Seeger per foro	(Ø90)
14	10	DIN 912	Hexagon socket bolt	Innensechskantschraube	VTH	Vite T.C.E.I.	(M8x25)
15	20	DIN 125-A	Washer	Unterlegscheibe	Rondelle	Rondella bisellata	(M8)
	10	DIN 127-B	Elastic washer	Elastische Scheibe	Rondelle élastique	Rosetta elastica	(M8)
16	1		Oil plug kit	Ölschraubensatz	Kit lubrification	Kit tappi lubrificazione	13008330A (3/8")
2	1		Breather plug	Entlüftungsschraube	Bouchon reniflard	Tappo di carico e sfiato	(3/8")
20	1		Oil outlet plug	Ablassschraube	Bouchon de vidange	Tappo di scarico	(3/8")
	1		Oil level plug	Ölstandschraube	Bouchon de niveau	Indicatore di livello a vista	(3/8")
			Casing	Gehäuse	Corps réducteur	Corpo riduttore	
	1		Input casing	Gehäuse Eingangsseite	Corps côté entrée	Corpo lato entrata	20920881A
	1		Output casing	Gehäuse Abtriebsseite	Corps côté sortie	Corpo lato uscita	20920891A

Gear reduction head series
Getriebe Serien
Tête motrice série
Testata motrice serie

S 25

Code

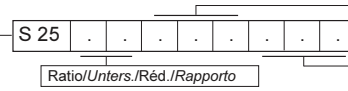
 GR. Motor size
Motore

 Type Output - Abtrieb
Sortie - Uscita

Item Quant. Pos. Menge	Standards Normen Normes Norme	DESCRIPTION	BENENNUNG	DESIGNATION	DENOMINAZIONE	Code
		Input	Eingang	Entrée	Entrata PAM	
		Motor size 090	Baugröße 090	Bride moteur 090	Grandezza motore 090	
29	1	Input flange	Eingangsfansch	Bride entrée	Flangia entrata	20924071A
9	1	Hollow shaft	Hohlwelle	Embout entrée	Boccola entrata	209QD031A
	6	Hexagon socket bolt	Innensechskantschraube	Vis	Vite T.C.E.I.	(M12x35)
	4	Hexagon socket bolt	Sechskantschraube	Vis	Vite T.C.E.I.	(M10x30)
	4	Washer	Unterlegscheibe	Rondelle	Rondella	(M10)
	4	Elastic washer	Elastische Scheibe	Rondelle élastique	Rondella elastica	(M10)
		Input	Eingang	Entrée	Entrata PAM	
		Motor size 100 - 112	Baugröße 100 - 112	Bride moteur 100 - 112	Grandezza motore 100 - 112	
29	1	Input flange	Eingangsfansch	Bride entrée	Flangia entrata	20924101A
9	1	Hollow shaft	Hohlwelle	Embout entrée	Boccola entrata	209QD041A
	6	Hexagon socket bolt	Innensechskantschraube	Vis	Vite T.C.E.I.	(M12x35)
	4	Hexagon bolt	Sechskantschraube	Vis	Vite T.E.	(M10x30)
	4	Washer	Unterlegscheibe	Rondelle	Rondella	(M10)
	4	Elastic washer	Elastische Scheibe	Rondelle élastique	Rondella elastica	(M10)
		Input	Eingang	Entrée	Entrata PAM	
		Motor size 132	Baugröße 132	Bride moteur 132	Grandezza motore 132	
29	1	Input flange	Eingangsfansch	Bride entrée	Flangia entrata	20924131A
9	1	Hollow shaft	Hohlwelle	Embout entrée	Boccola entrata	209QD051A
	6	Hexagon socket bolt	Innensechskantschraube	Vis	Vite T.C.E.I.	(M12x35)
	4	Hexagon bolt	Sechskantschraube	Vis	Vite T.E.	(M10x30)
	4	Washer	Unterlegscheibe	Rondelle	Rondella	(M10)
	4	Elastic washer	Elastische Scheibe	Rondelle élastique	Rondella elastica	(M10)
		Input	Eingang	Entrée	Entrata PAM	
		Motor size 160	Baugröße 160	Bride moteur 160	Grandezza motore 160	
29	1	Input flange	Eingangsfansch	Bride entrée	Flangia entrata	20924151A
9	1	Hollow shaft	Hohlwelle	Embout entrée	Boccola entrata	209QD011A
	6	Hexagon socket bolt	Innensechskantschraube	Vis	Vite T.C.E.I.	(M12x35)
	4	Hexagon bolt	Sechskantschraube	Vis	Vite T.E.	(M10x30)
	4	Washer	Unterlegscheibe	Rondelle	Rondella	(M10)
	4	Elastic washer	Elastische Scheibe	Rondelle élastique	Rondella elastica	(M10)
		Input	Eingang	Entrée	Entrata PAM	
		Motor size 180	Baugröße 180	Bride moteur 180	Grandezza motore 180	
29		Input flange	Eingangsfansch	Bride entrée	Flangia entrata	20924151A
9		Hollow shaft	Hohlwelle	Embout entrée	Boccola entrata	209QD061A
	DIN 912	Hexagon socket bolt	Innensechskantschraube	Vis	Vite T.C.E.I.	(M12x35)
	DIN 912	Hexagon socket bolt	Sechskantschraube	Vis	Vite T.C.E.I.	(M10x30)
	DIN 125 A	Washer	Unterlegscheibe	Rondelle	Rondella	(M10)
	DIN 127 B	Elastic washer	Elastische Scheibe	Rondelle élastique	Rondella elastica	(M10)

Gear reduction head series
Getriebe Serien
Tête motrice série
Testata motrice serie

S 25

Code

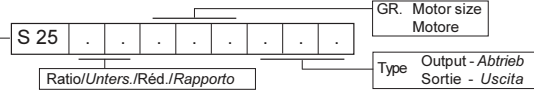

Item Pos.	Quant. Menge	Standards Normen Normes Norme	DESCRIPTION	BENENNUNG	DESIGNATION	DENOMINAZIONE	Code
9	1		Input "C" Shaft	Eingang "C" Welle	Entrée "C" Arbre entrée	Entrata "C" Albero entrata	209QD021A
			Input gears Ratio 1/10	Radsatz Eingangsseite Untersetzung 1:10	Engrainages d'entrée Réduction 1:10	Sottogruppo coppia entrata Rapporto riduttore 1:10	10752200A
18			Pinion Gear wheel	Ritzel Zahnrad	Pignon Roue dentée	Pignone Corona	
19		DIN 6885	Parallel key	Passfeder	Clavette	Linguetta	
			Input gear kit Ratio 1/12	Radsatz Eingangsseite Untersetzung 1:12	Engrainages d'entrée Réduction 1:12	Sottogruppo coppia entrata Rapporto riduttore 1:12	10752150A
18			Pinion	Ritzel	Pignon	Pignone	
19			Gear wheel	Zahnrad	Roue dentée	Corona	
22		DIN 6885	Parallel key	Passfeder	Clavette	Linguetta	

Gear reduction head series
Getriebe Serien
Tête motrice série
Testata motrice serie

S 25

Code

S 25

Ratio/Unters./Réd./Rapporto

 GR. Motor size
Motore

 Type Output - Abtrieb
Sortie - Uscita

Item Quant. Pos. Menge	Standards Normen Normes Norme	DESCRIPTION	BENENNUNG	DESIGNATION	DENOMINAZIONE	Code
		Input gear	Radsatz Eingangsseite	Engrainages d'entrée	Sottogruppo coppia entrata	10752160A
		Ratio 1/16	Untersetzung 1:16	Réduction 1:16	Rapporto riduttore 1:16	
18		Pinion	Ritzel	Pignon	Pignone	
19		Gear wheel	Zahnrad	Roue dentée	Corona	
22	DIN 6885	Parallel key	Passfeder	Clavette	Linguetta	
		Input gear	Radsatz Eingangsseite	Engrainages d'entrée	Sottogruppo coppia entrata	10752170A
		Ratio 1/20	Untersetzung 1:20	Réduction 1:20	Rapporto riduttore 1:20	
18		Pinion	Ritzel	Pignon	Pignone	
19		Gear wheel	Zahnrad	Roue dentée	Corona	
22	DIN 6885	Parallel key	Passfeder	Clavette	Linguetta	
		Input gear	Radsatz Eingangsseite	Engrainages d'entrée	Sottogruppo coppia entrata	10752180A
		Ratio 1/25	Untersetzung 1:25	Réduction 1:25	Rapporto riduttore 1:25	
18		Pinion	Ritzel	Pignon	Pignone	
19		Gear wheel	Zahnrad	Roue dentée	Corona	
22	DIN 6885	Parallel key	Passfeder	Clavette	Linguetta	
		Input gear	Radsatz Eingangsseite	Engrainages d'entrée	Sottogruppo coppia entrata	10752180A
		Ratio 1/30	Untersetzung 1:30	Réduction 1:30	Rapporto riduttore 1:30	
18		Pinion	Ritzel	Pignon	Pignone	
19		Gear wheel	Zahnrad	Roue dentée	Corona	
22	DIN 6885	Parallel key	Passfeder	Clavette	Linguetta	
		Input gear	Radsatz Eingangsseite	Engrainages d'entrée	Sottogruppo coppia entrata	10752190A
		Ratio 1/40	Untersetzung 1:40	Réduction 1:40	Rapporto riduttore 1:40	
18		Pinion	Ritzel	Pignon	Pignone	
19		Gear wheel	Zahnrad	Roue dentée	Corona	
22	DIN 6885	Parallel key	Passfeder	Clavette	Linguetta	
		Output gear	Radsatz Ausgangsseite	Engrainages sortie	Sottogruppo coppia uscita	10752300A
		Ratio 1/7 - 1/25	Untersetzung 1:7 - 1:25	Réduction 1:7 - 1:25	Rapporto riduttore 1:7 - 1:25	
7		Pinion	Ritzel	Pignon	Pignone	
4		Gear wheel	Zahnrad	Roue dentée	Corona	
6	DIN 6885	Parallel key	Passfeder	Clavette	Linguetta	
		Spacer	Distanzring	Entretoise	Distanziale	20984831A
		Spacer	Distanzring	Entretoise	Distanziale	20984841A
		Spacer	Distanzring	Entretoise	Distanziale	20984851A

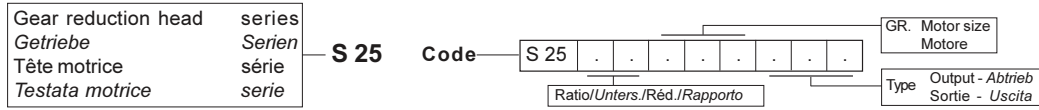

Item Quant. Pos. Menge	Standards Normen Normes Norme	DESCRIPTION	BENENNUNG	DESIGNATION	DENOMINAZIONE	Code
		Output gear	Radsatz Ausgangsseite	Engrainages sortie	Sottogruppo coppia uscita	10752130A
		Ratio 1/30 - 1/40	Untersetzung 1:30 - 1:40	Réduction 1:30 - 1:40	Rapporto riduttore 1:30 - 1:40	
7		Pinion	Rizel	Pignon	Pignone	
4		Gear wheel	Zahnrad	Roue dentée	Corona	
6	DIN 6885	Parallel key	Passfeder	Clavette	Linguetta	
		Spacer	Distanzring	Entretoise	Distanziale	20984831A
		Spacer	Distanzring	Entretoise	Distanziale	20984841A
		Spacer	Distanzring	Entretoise	Distanziale	20984851A
		Output A 4	Ausgang A 4	Sortie A 4	Uscita A 4	
30		Output flange	Ausgangsfansch	Bride sortie	Flangia uscita	20923161B
25		Output shaft	Abtriebswelle	Arbre sortie	Albero uscita	20947391A
1	DIN 933	Hexagon bolt	Sechskantschraube	VHT	Vite T.E.	(M12x170)
4	DIN 127 B	Elastic washer	Elastische Scheibe	Rondelle élastique	Rosetta elastica	(M12)
4	DIN 125 A	Washer	Scheibe	Rondelle biseautée	Rondella bisellata	(M12)
4	DIN 934	Hexagon nut	Sechskantmutter	Écrou hexagon	Dado esagonale	(M12)
1	DIN 933	Hexagon bolt	Sechskantschraube	VHT	Vite T.E.	(M12x45)
4	DIN 125 A	Washer	Unterlegscheibe	Rondelle	Rondella	(M12)
4	DIN 127 B	Elastic washer	Elastische Scheibe	Rondelle élastique	Rosetta elastica	(M12)
4		Felt ring	Filzring	Joint garniture	Anello feltro	20989261A

Gear reduction head	series
Getriebe	Serien
Tête motrice	série
Testata motrice	serie

S 25
Code

S	25
---	----	---	---	---	---	---	---	---	---

Ratio/Unters./Réd./Rapporto

 GR. Motor size
Motore

 Type Output - Abtrieb
Sortie - Uscita

Item Quant. Pos. Menge	Standards Normen Normes Norme	DESCRIPTION	BENENNUNG	DESIGNATION	DENOMINAZIONE	Code
30		Output A 6	Ausgang A 6	Sortie A 6	Uscita A 6	
25		Output flange	Ausgangsflansch	Bride sortie	Flangia uscita	20923161B
		Output shaft	Abtriebswelle	Arbre sortie	Albero uscita	20947421A
4	DIN 933	Hexagon bolt	Sechskantschraube	VTH	Vite T.E.	(M12x170)
4	DIN 127 B	Elastic washer	Elastische Scheibe	Rondelle élastique	Rosetta elastica	(M12)
4	DIN 125 A	Washer	Scheibe	Rondelle biseautée	Rondella bisellata	(M12)
1		Hexagonal nut	Hexagonal nut	Écrou hexagon	Dado esagonale	(M12)
4	DIN 933	Hexagon Bolt	Sechskantschraube	VHT	Vite T.E.	(M12x45)
4	DIN 125 A	Washer	Unterlegscheibe	Rondelle	Rondella	(M12)
4	DIN 127 B	Elastic washer	Elastische Scheibe	Rondelle élastique	Rosetta elastica	(M12)
		Felt ring	Filzring	Joint garniture	Anello feltro	20989261B
		Output K	Ausgang K	Sortie K	Uscita K	
30		Output flange	Ausgangsflansch	Bride sortie	Flangia uscita	20924311A
25		Output shaft	Abtriebswelle	Arbre sortie	Albero uscita	20947431A
4	DIN 933	Hexagon bolt	Sechskantschraube	VTH	Vite T.E.	(M12x170)
4	DIN 127 B	Elastic washer	Elastische Scheibe	Rondelle élastique	Rosetta elastica	(M12)
4	DIN 125 A	Washer	Scheibe	Rondelle biseautée	Rondella bisellata	(M12)
1	DIN 934	Hexagonal nut	Hexagonal nut	Écrou hexagon	Dado esagonale	(M12)
4	DIN 933	Hexagon Bolt	Sechskantschraube	VHT	Vite T.E.	(M12x45)
4	DIN 125 A	Washer	Unterlegscheibe	Rondelle	Rondella	(M12)
4	DIN 127 B	Elastic washer	Elastische Scheibe	Rondelle élastique	Rosetta elastica	(M12)

Gear reduction head	series	S 27
Getriebe	Serien	
Tête motrice	série	
Testata motrice	serie	

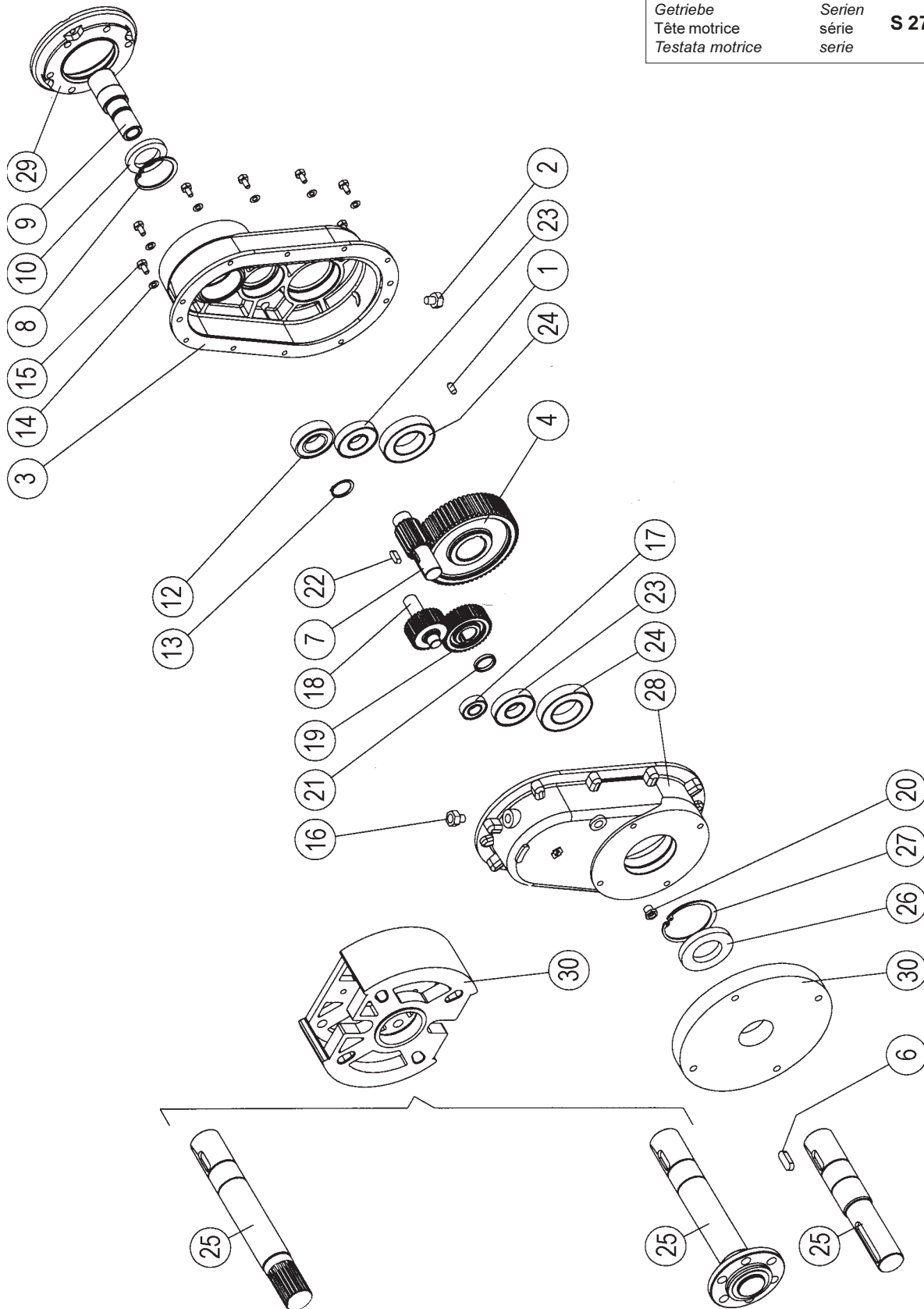



WAM®

MU - BU

- SPARE PARTS
- ERSATZLEIKATALOG
- PIECES DE RECHANGE
- PEZZI DI RICAMBIO

12.04

3

WA.01520.R. 37

Gear reduction head series
Getriebe Serien
Tête motrice série
Testata motrice serie

S 27

Code

S 27

GR. Motor size
Motore

Ratio/Unters./Réd./Rapporto

Type Output - Abtrieb
Sortie - Uscita

Item Quant. Pos. Menge	Standards Normen Normes Norme	DESCRIPTION	BENENNUNG	DESIGNATION	DENOMINAZIONE	Code
		Sealing kit 112/132/160/180	Dichtungssatz 112/132/160/180	Kit étanchéité 112/132/160/180	Kit tenuta 112/132/160/180	13009770A
1		Gasket	Flachdichtung	Garniture	Guarnizione riduttore	
26	DIN 3760 NB	Rotary shaft seal	Wellendichtring	Joint d'étanchéité	Anello di tenuta	(110x60x10)
10	DIN 3760 NB	Rotary shaft seal	Wellendichtring	Joint d'étanchéité	Anello di tenuta	(100x70x10)
1	DIN 7	Cylindrical pin	Zylinderstift	Goupille cylindrique	Spina cilindrica	(10x20)
		Sealing kit 200/225	Dichtungssatz 200/225	Kit étanchéité 200/225	Kit tenuta 200/225	13009770B
1		Gasket	Flachdichtung	Garniture	Guarnizione riduttore	
26	DIN 3760 NB	Rotary shaft seal	Wellendichtring	Joint d'étanchéité	Anello di tenuta	(110x60x10)
10	DIN 3760 NB	Rotary shaft seal	Wellendichtring	Joint d'étanchéité	Anello di tenuta	(100x80x10)
1	DIN 7	Cylindrical pin	Zylinderstift	Goupille cylindrique	Spina cilindrica	(10x20)
		Bearing kit	Lagersatz	Kit roulements	Kit cuscinetti	13009750A
12	1	Radial bearing	Radialirillenkugellager	Roulement radial	Cuscinetto radiale	6309 (45x100x25)
23	2	Radial bearing	Radialirillenkugellager	Roulement radial	Cuscinetto radiale	6307 (35x80x21)
24	2	Radial bearing	Radialirillenkugellager	Roulement radial	Cuscinetto radiale	6212 (60x110x22)
17	1	Radial bearing	Radialirillenkugellager	Roulement radial	Cuscinetto radiale	6305 (25x62x17)
		Retaining ring kit	Satz sicherungsringe	Kit circlip "seeger"	Kit seeger	13009760A
13	DIN 471	Retaining ring for shaft	Seegerring für Welle	Seeger pour arbre	Seeger per albero	(Ø 45)
27	DIN 472	Retaining ring for bore	Seegerring für Bohrung	Seeger pour perçage	Seeger per foro	(Ø 100)
8	DIN 472	Retaining ring for bore	Seegerring für Bohrung	Seeger pour perçage	Seeger per foro	(Ø 110)
14	DIN 912	Hexagonal socket bolt	Innensechskantschraube	Vis	Vite T.C.E.I.	(M12 x35)
15	DIN 125A	Washer	Unterlegscheibe	Rondelle	Rondella bisellata	(M12)
		Elastic washer	Elastische Scheibe	Rondelle élastique	Rosetta elastica	(M12)
		Oil plug kit	Ölschraubensatz	Kit lubrification	Kit tappi lubrificazione	13008330A
16	1	Breather plug	Entlüftungsschraube	Bouchon reniflard	Tappo di carico e sfiato	(3/8")
2	1	Oil outlet plug	Ablassschraube	Bouchon de vidange	Tappo di scarico	(3/8")
20	1	Oil level plug	Ölastandschraube	Bouchon de niveau	Indicatore di livello a vista	(3/8")
		Casing	Gehäuse	Corps réducteur	Corpo riduttore	
3	1	Input casing	Gehäuse Eingangsseite	Corps côté entrée	Corpo lato entrata	20920971A
28	1	Output casing	Gehäuse Atriebsseite	Corps côté sortie	Corpo lato uscita	20920981A
		Input	Eingang	Entrée	Entrata PAM	
		Motor size 112	Baugrosse 112	Bride moteur 112	Grandeza motore 112	
29	1	Input flange	Eingangsfansch	Bride entrée	Flangia entrata	20924111A
9	1	Hollow shaft	Hohlwelle	Embout entrée	Boccola entrata	20970501A
6	DIN 912	Hexagonal socket bolt	Innensechskantschraube	Vis	Vite T.C.E.I.	(M12 x50)
4	DIN 912	Hexagonal socket bolt	Innensechskantschraube	Vis	Vite T.C.E.I.	(M12x35)
4	DIN 125A	Washer	Unterlegscheibe	Rondelle	Rondelle	(M12)
4	DIN 127B	Elastic washer	Elastische Scheibe	Rondelle élastique	Rondella elastica	(M12)



WAM®

MU - BU

- SPARE PARTS
- ERSATZLEIKATALOG
- PIÈCES DE RECHANGE
- PEZZI DI RICAMBIO

12.04

3

WA.01520 R. 38

Gear reduction head series
 Getriebe Serien
 Tête motrice série
 Testata motrice serie

S 27

Code

S 27

Ratio/Unters./Réd./Rapporto

GR. Motor size
Motore

Type Output - Abtrieb
Sortie - Uscita

Item Pos.	Standards Quant. Menge	Normen Normes	Norme	DESCRIPTION	BENENNUNG	DESIGNATION	DENOMINAZIONE	Code
				Input	Eingang	Entrée	Entrata PAM	
29	1			Motor size 132	Baugröße 132	Bride moteur 132	Grandezza motore 132	20924141A
9	1			Input flange	Eingangsfansch	Bride entrée	Flangia entrata	20970461A
				Hollow shaft	Hohlwelle	Embout entrée	Boccola entrata	(M10x50)
	6	DIN 912		Hexagon socket bolt	Innensechskantschraube	Vis	Vite T.C.E.I.	(M10x30)
	4	DIN 912		Hexagon socket bolt	Innensechskantschraube	Vis	Vite T.C.E.I.	(M10)
	4	DIN 125A		Washer	Unterlegscheibe	Rondelle	Rondella	(M10)
	4	DIN 127B		Elastic washer	Elastische Scheibe	Rondelle élastique	Rondella elastica	(M10)
				Input	Eingang	Entrée	Entrata PAM	
29	1			Motor size 160	Baugröße 160	Bride moteur 160	Grandezza motore 160	20924161A
9	1			Input flange	Eingangsfansch	Bride entrée	Flangia entrata	20970471A
				Hollow shaft	Hohlwelle	Embout entrée	Boccola entrata	(M10x50)
	6	DIN 912		Hexagon socket bolt	Innensechskantschraube	Vis	Vite T.C.E.I.	(M10x30)
	4	DIN 912		Hexagon socket bolt	Innensechskantschraube	Vis	Vite T.C.E.I.	(M10)
	4	DIN 125A		Washer	Unterlegscheibe	Rondelle	Rondella	(M10)
	4	DIN 127B		Elastic washer	Elastische Scheibe	Rondelle élastique	Rondella elastica	(M10)
				Input	Eingang	Entrée	Entrata PAM	
29	1			Motor size 180	Baugröße 180	Bride moteur 180	Grandezza motore 180	20924161A
9	1			Input flange	Eingangsfansch	Bride entrée	Flangia entrata	20970481A
				Hollow shaft	Hohlwelle	Embout entrée	Boccola entrata	(M10x50)
	6	DIN 912		Hexagon socket bolt	Innensechskantschraube	Vis	Vite T.C.E.I.	(M10x30)
	4	DIN 912		Hexagon socket bolt	Innensechskantschraube	Vis	Vite T.C.E.I.	(M10)
	4	DIN 125A		Washer	Unterlegscheibe	Rondelle	Rondella	(M10)
	4	DIN 127B		Elastic washer	Elastische Scheibe	Rondelle élastique	Rondella elastica	(M10)
				Input	Eingang	Entrée	Entrata PAM	
29	1			Motor size 200	Baugröße 200	Bride moteur 200	Grandezza motore 200	20924561A
9	1			Input flange	Eingangsfansch	Bride entrée	Flangia entrata	20970491A
				Hollow shaft	Hohlwelle	Embout entrée	Boccola entrata	(M10x50)
	6	DIN 912		Hexagon socket bolt	Innensechskantschraube	Vis	Vite T.C.E.I.	(M10x30)
	4	DIN 912		Hexagon socket bolt	Innensechskantschraube	Vis	Vite T.C.E.I.	(M10)
	4	DIN 125A		Washer	Unterlegscheibe	Rondelle	Rondella	(M10)
	4	DIN 127B		Elastic washer	Elastische Scheibe	Rondelle élastique	Rondella elastica	(M10)
9				Input "C"	Eingang "C"	Entrée "C"	Entrata "C"	20970451A
	1			Shaft	Welle	Arbre entrée	Albero entrata	

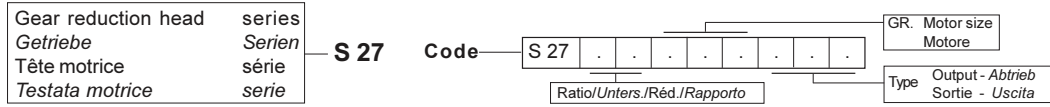

Item Quant.	Standards	DESCRIPTION	BENENNUNG	DESIGNATION	DENOMINAZIONE	Code
Pos. Menge	Normen Normes Norme					
18	1	Input gear kit	Radsatz Eingangsseite	Engrainages d'entrée	Sottogruppo coppia entrata	10752770A
19	1	Ratio 1/10	Untersetzung 1:10	Réduction 1:10	Rapporto riduttore 1:10	
22	1	Pinion	Ritzel	Pignon	Pignone	
19	1	Gear wheel	Zahnrad	Roue dentée	Corona	
22	1	Parallel key	Passfeder	Clavette	Linguetta	(12x8x32)
		Input gear kit	Radsatz Eingangsseite	Engrainages d'entrée	Sottogruppo coppia entrata	10752780A
18	1	Ratio 1/12	Untersetzung 1:12	Réduction 1:12	Rapporto riduttore 1:12	
19	1	Pinion	Ritzel	Pignon	Pignone	
22	1	Gear wheel	Zahnrad	Roue dentée	Corona	
		Parallel key	Passfeder	Clavette	Linguetta	(12x8x32)

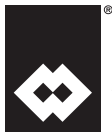

WAM®

MU - BU

- SPARE PARTS
- ERSATZLEIKATALOG
- PIÈCES DE RECHANGE
- PEZZI DI RICAMBIO

12.04



WA.01520 R. 40

Gear reduction head series
 Getriebe Serien
 Tête motrice série
 Testata motrice serie

S 27 Code

S 27

GR. Motor size
Motore

Ratio/Unters./Réd./Rapporto

Type Output - Abtrieb
Sortie - Uscita

Item Pos.	Standards Quant. Normen Menge Normes Norme	DESCRIPTION	BENENNUNG	DESIGNATION	DENOMINAZIONE	Code
		Input gear	Radsatz Eingangsseite	Engrainages d'entrée	Sottogruppo coppia entrata	10752790A
		Ratio 1/16	Untersetzung 1:16	Réduction 1:16	Rapporto riduttore 1:16	
18	1	Pinion	Ritzel	Pignon	Pignone	
19	1	Gear wheel	Zahnrad	Roue dentée	Corona	(12x8x32)
22	1	Parallel key	Passfeder	Clavette	Linguetta	10752800A
		Input gear	Radsatz Eingangsseite	Engrainages d'entrée	Sottogruppo coppia entrata	
		Ratio 1/20	Untersetzung 1:20	Réduction 1:20	Rapporto riduttore 1:20	
18	1	Pinion	Ritzel	Pignon	Pignone	
19	1	Gear wheel	Zahnrad	Roue dentée	Corona	(12x8x32)
22	1	Parallel key	Passfeder	Clavette	Linguetta	10752810A
		Input gear	Radsatz Eingangsseite	Engrainages d'entrée	Sottogruppo coppia entrata	
		Ratio 1/25	Untersetzung 1:25	Réduction 1:25	Rapporto riduttore 1:25	
18	1	Pinion	Ritzel	Pignon	Pignone	
19	1	Gear wheel	Zahnrad	Roue dentée	Corona	
22	1	Parallel key	Passfeder	Clavette	Linguetta	(12x8x32)
		Input gear	Radsatz Eingangsseite	Engrainages d'entrée	Sottogruppo coppia entrata	10752820A
		Ratio 1/30	Untersetzung 1:30	Réduction 1:30	Rapporto riduttore 1:30	
18	1	Pinion	Ritzel	Pignon	Pignone	
19	1	Gear wheel	Zahnrad	Roue dentée	Corona	(12x8x32)
22	1	Parallel key	Passfeder	Clavette	Linguetta	10752830A
		Input gear	Radsatz Eingangsseite	Engrainages d'entrée	Sottogruppo coppia entrata	
		Ratio 1/40	Untersetzung 1:40	Réduction 1:40	Rapporto riduttore 1:40	
18	1	Pinion	Ritzel	Pignon	Pignone	
19	1	Gear wheel	Zahnrad	Roue dentée	Corona	(12x8x32)
22	1	Parallel key	Passfeder	Clavette	Linguetta	10752680A
		Output gear 1/4 - 1/25	Radsatz Ausgangsseite 1:4 - 1:25	Engrainages sortie 1:4 - 1:25	Sottogruppo coppia uscita 1:4 - 1:25	
7		Pinion	Ritzel	Pignon	Pignone	
4		Gear wheel	Zahnrad	Roue dentée	Corona	(8x7x22)
6		Parallel key	Passfeder	Clavette	Linguetta	20984921A
21		Spacer	Distanzring	Entretoise	Distanziale	20984931A
5		Spacer	Distanzring	Entretoise	Distanziale	20984931A
		Output gear 1/30 - 1/40	Radsatz Ausgangsseite 1:30 - 1:40	Engrainages sortie 1:30 - 1:40	Sottogruppo coppia uscita 1:30 - 1:40	10752700A
7		Pinion	Ritzel	Pignon	Pignone	
4		Gear wheel	Zahnrad	Roue dentée	Corona	(8x7x22)
6		Parallel key	Passfeder	Clavette	Linguetta	20984921A
21		Spacer	Distanzring	Entretoise	Distanziale	20984931A
5		Spacer	Distanzring	Entretoise	Distanziale	20984931A

Gear reduction head series
Getriebe Serien
Tête motrice série
Testata motrice serie

S 27

Code

S 27
Ratio/Unters./Réd./Rapporto

GR. Motor size
Motore

Type Output - Abtrieb
Sortie - Uscita

Item Pos.	Quant. Menge	Standards Normen Norme	DESCRIPTION	BENENNING	DESIGNATION	DENOMINAZIONE	Code
30	1		Output A 4	Ausgang A 4	Sortie A 4	Uscita A 4	20924181A
25	1		Output flange	Ausgangsflansch	Bride sortie	Flangia uscita	20947551A
	4	DIN 933	Output shaft	Abtriebswelle	Arbre sortie	Albero uscita	(M16x210)
	4	DIN 933	Hexagon bolt	Sechskantschraube	VHT	Vite T.E.	(M16)
	1	DIN 934	Hexagon nut	Sechskantmutter	Écrou hexagon	Dado esagonale	(M16x45)
	4	DIN 933	Hexagon bolt	Sechskantschraube	VHT	Vite T.E.	(M16)
	4	DIN 125B	Elastic washer	Elastische Scheibe	Rondelle élastique	Rosetta elastica	(M16)
	4	DIN 127A	Washer	Scheibe	Rondelle	Rondella bisellata	(M16)
	1		Felt ring	Filzring	Joint garniture	Anello di feltro	20989281A
30	1		Output A 6	Ausgang A 6	Sortie A 6	Uscita A 6	20924181A
25	1		Output flange	Ausgangsflansch	Bride sortie	Flangia uscita	20947691A
	4	DIN 933	Output shaft	Abtriebswelle	Arbre sortie	Albero uscita	(M10x150)
	1	DIN 934	Hexagon nut	Sechskantmutter	Écrou hexagon	Dado esagonale	(M16)
	4	DIN 933	Hexagon bolt	Sechskantschraube	VHT	Vite T.E.	(M16x45)
	4	DIN 125B	Elastic washer	Elastische Scheibe	Rondelle élastique	Rosetta elastica	(M 10)
	4	DIN 127A	Washer	Scheibe	Rondelle	Rondella bisellata	(M 10)
	1		Felt ring	Filzring	Joint garniture	Anello di feltro	20989281A
30	1		Output K	Ausgang K	Sortie K	Uscita K	20924321A
25	1		Output flange	Ausgangsflansch	Bride sortie	Flangia uscita	20947681A
	4	DIN 933	Output shaft	Abtriebswelle	Arbre sortie	Albero uscita	(M16x210)
	4	DIN 127B	Hexagon bolt	Sechskantschraube	VHT	Vite T.E.	(M16)
	4	DIN 125A	Elastic washer	Elastische Scheibe	Rondelle élastique	Rosetta elastica	(M16)
	8	DIN 125A	Washer	Scheibe	Rondelle	Rondella bisellata	(M16)
	4	DIN 912	Hexagon socket bolt	Innensechskantschraube	VHT	Vite T.C.E.I.	(M16x35)
	1	DIN 6885	Parallel key	Passfeder	Clavette	Linguetta	(16x10)

MW
MV
MZ
MY

COMPLETE ELECTRIC MOTOR - SERIES
 KOMPLETTER ELEKTROMOTOR - SERIE
 MOTEUR ELECTRIQUE COMPLET-SERIE
 MOTORE ELETTTRICO COMPLETO-SERIE

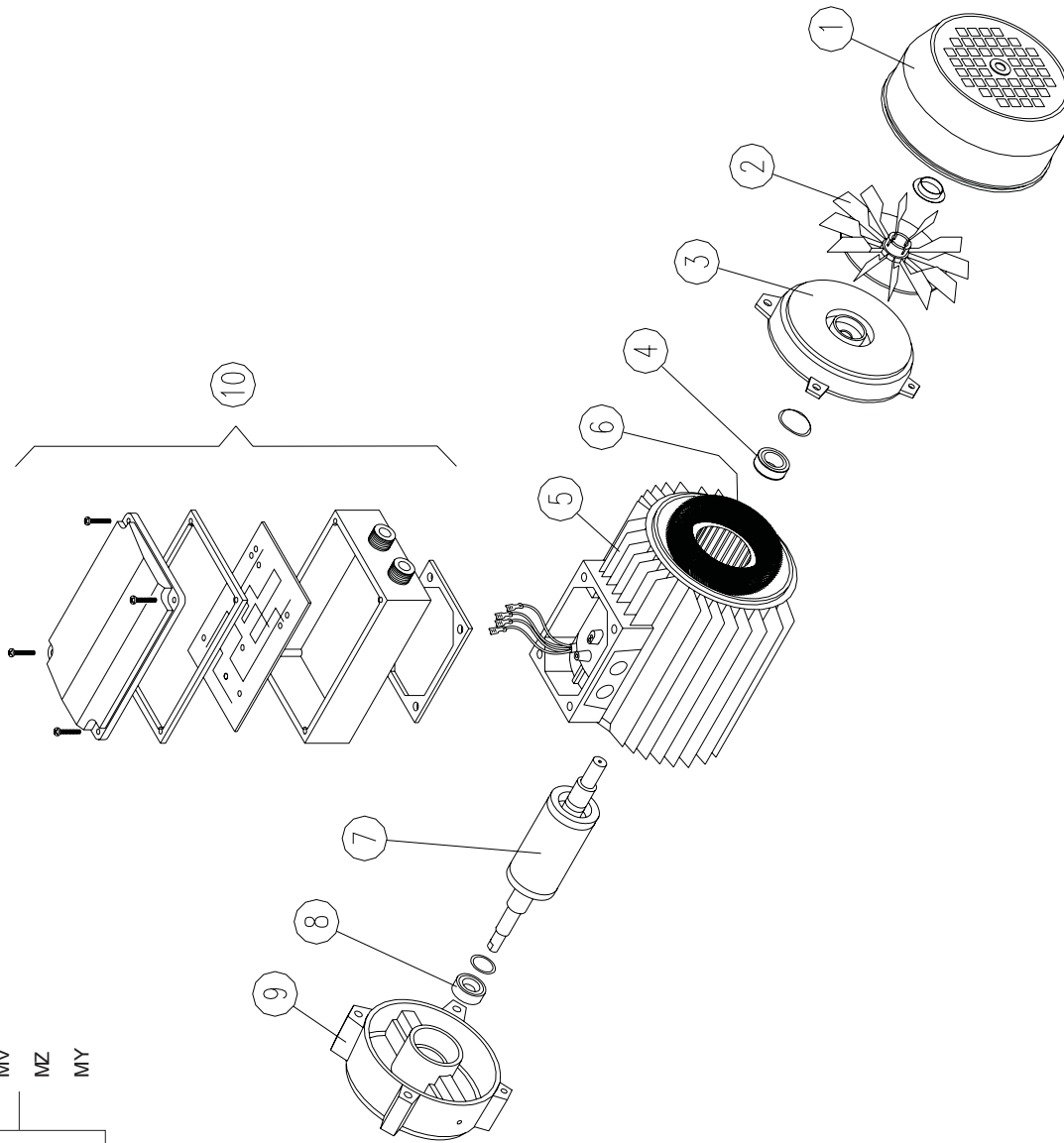

COMPLETE ELECTRIC MOTOR	- SERIES	MW
KOMPLETTER ELEKTROMOTOR	- SERIE	MV
MOTEUR ELECTRIQUE COMPLET	- SERIE	MZ
MOTORE ELETTRICO COMPLETO	- SERIE	MY

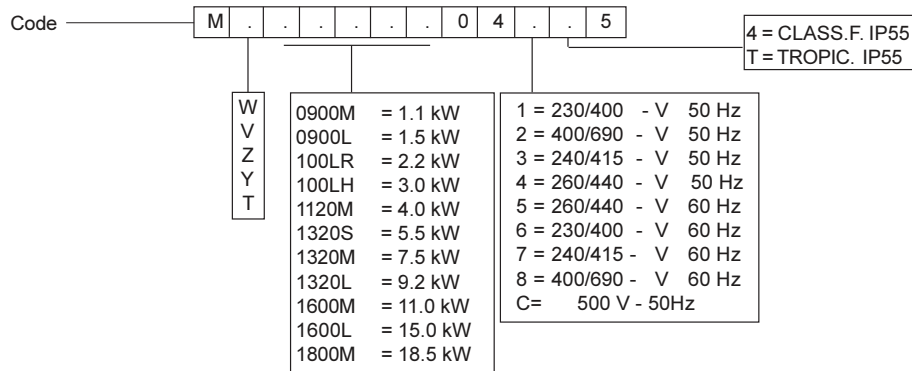

Item Pos.	Quant. Menge	DESCRIPTION	BENENNUNG	DESIGNATION	DENOMINAZIONE
1	1	Fan guard	Lüfterhaube	Carter	Copriventola
2	1	Fan	Lüfterflügel	Ventilateur	Ventola
3	1	Rear flange	Hinterer Flansch	Flasque postérieure	Calotta posteriore
4	1	Fan bearing	Lager	Roulement ventilateur	Cuscinetto posteriore
5	1	Casing	Lager Lüfterseite	Corps	Carcassa esterna
6	1	Stator	Ständer	Stator	Statore
7	1	Rotor	Rotor	Rotor	Rotore
8	1	Front bearing	Vorderes Lager	Roulement antérieur	Cuscinetto anteriore
9	1	Front flange	Vorderer Flansch	Flasque antérieure	Flangia anteriore
10	1	Flasque antérieure	Flangia anteriore	Boîte à bornes	Scatola morsettiara

IEC European standard motors with 4 poles, B5

IEC-Normmotore 4-polig in Bauform B5

Moteurs à normes européennes IEC à 4 poles B5

Motori a Norme IEC a 4 poli in forma B5